

Dimensions

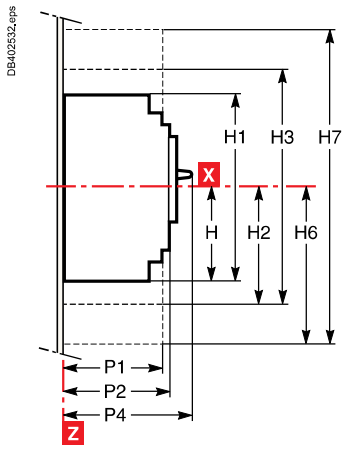

1 pole

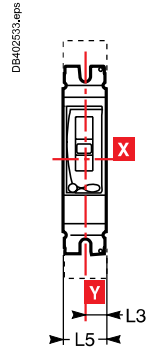

2 poles

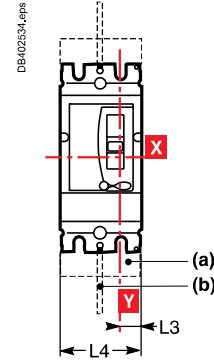

(a) Short terminal shields.
(b) Interphase barriers.

Mounting

On backplate

1 pole

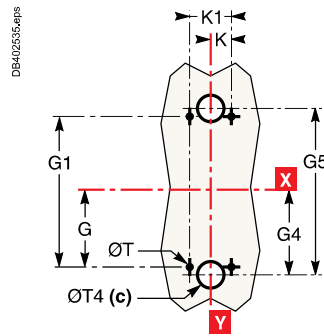

(c) For rear connection only.

2 poles

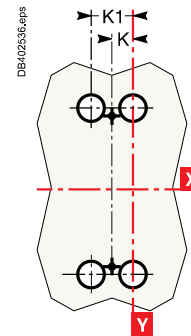

On rails

1 pole

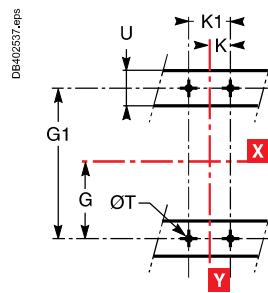

2 poles

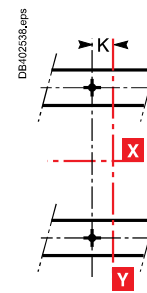

Front-panel cutout

On backplate

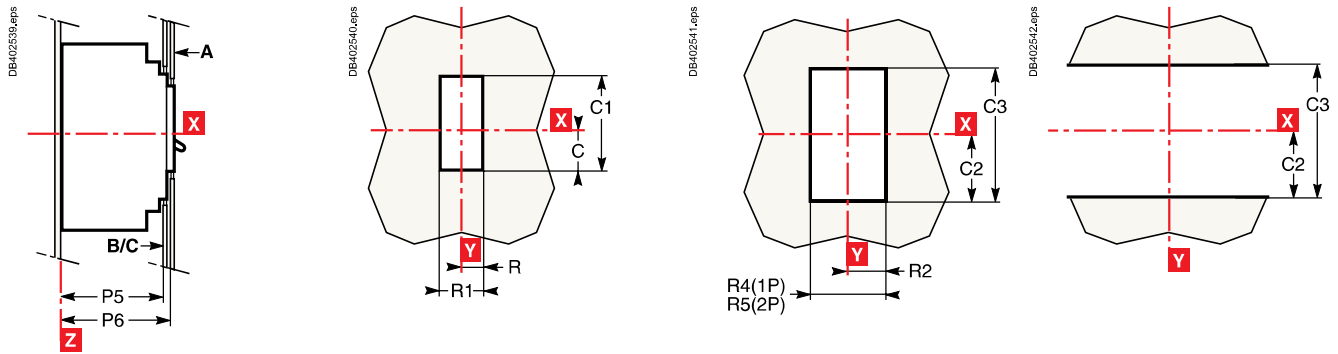

With escutcheon

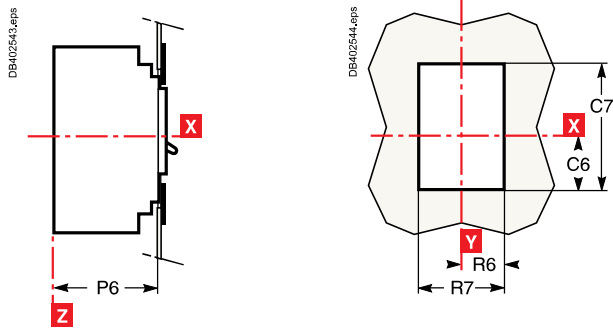

Dimensions (mm)

Type	C	C1	C2	C3	C6	C7	G	G1	G4	G5	H
NSX100/250	29	76	54	108	43	104	62.5	125	70	140	80.5
Type	H1	H2	H3	H4	H6	H7	K	K1	L3	L4	L5
NSX100/250	161	94	188	160.5	178.5	357	17.5	35	17.5	70	35
Type	P1	P2	P4	P5	P6	R	R1	R2	R4	R5	R6
NSX100/250	81	86	111	83	88	14.5	29	19	38	73	29
Type	R7	ØT	ØT4	U							
NSX100/250	58	6	22	≤ 32							

Dimensions

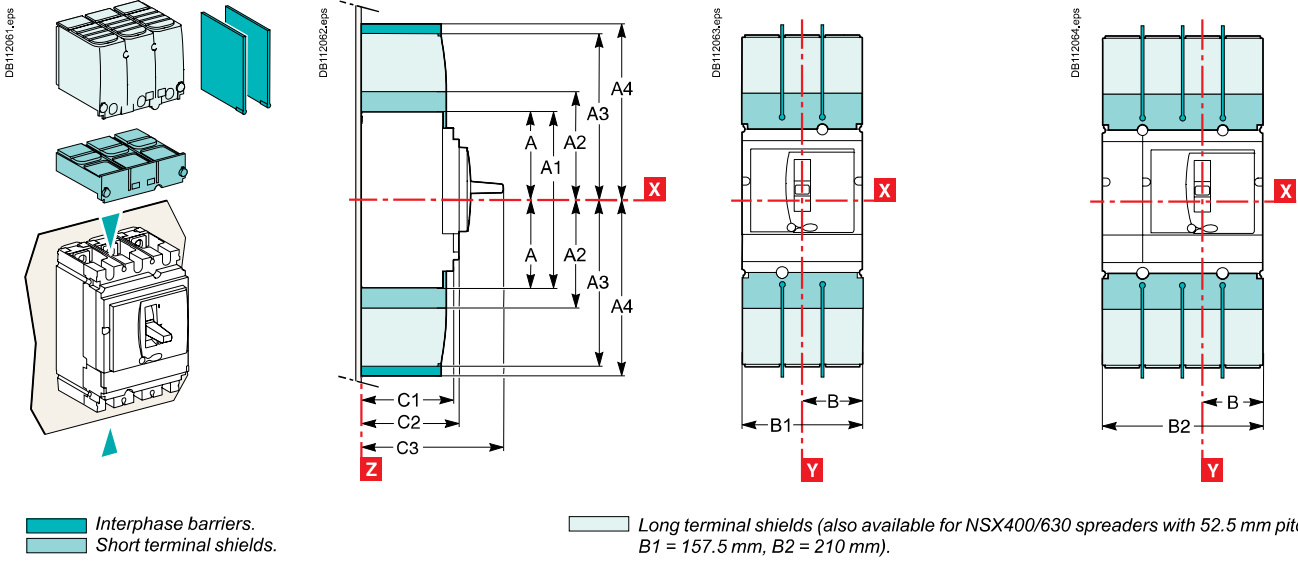

Mounting

On backplate

NSX100 to 250

NSX400/630⁽²⁾

NSX100 to 630⁽²⁾

2/3P

3P

4P

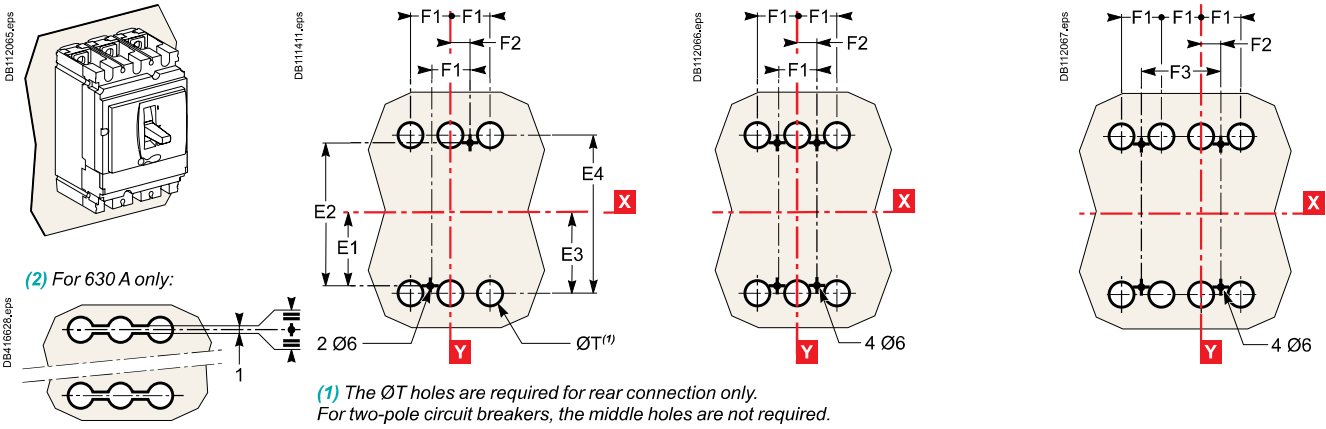

On rails

2/3P

3P

4P

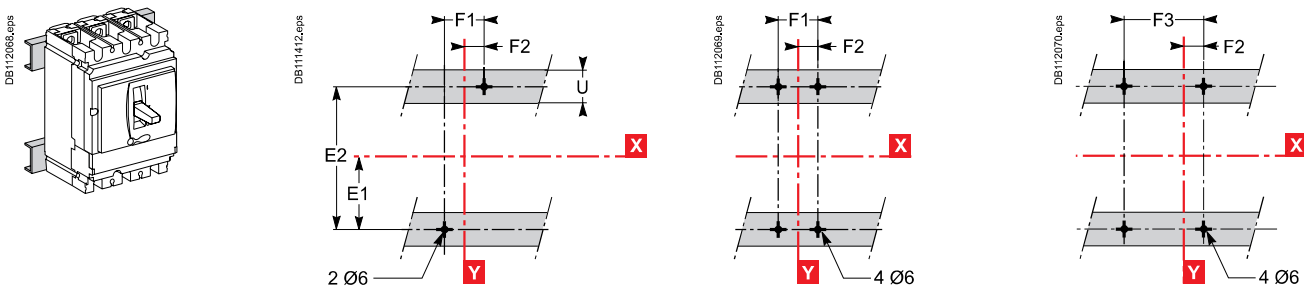

On DIN rail with adapter plate (NSX100 to 250)

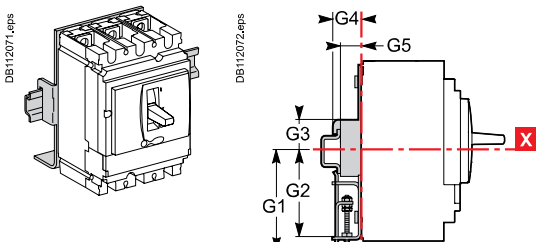

Vigicomact NSX100 to 630 fixed version

Dimensions

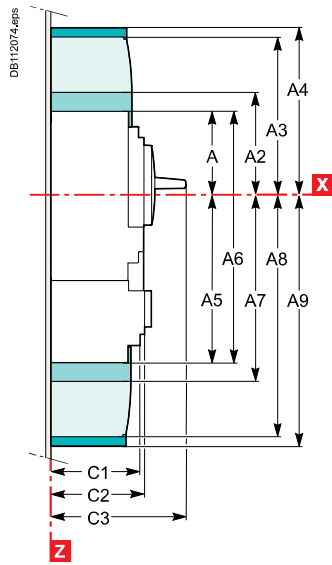
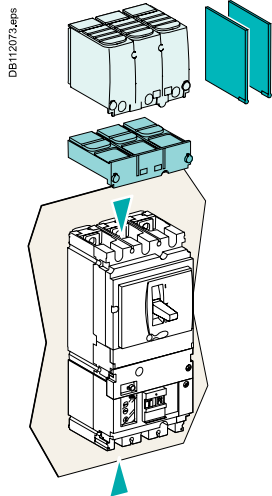

3/4P

NSX100 to 250

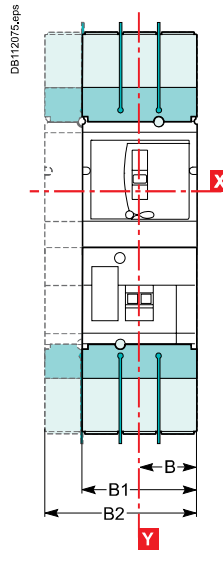

3/4P

NSX400/630

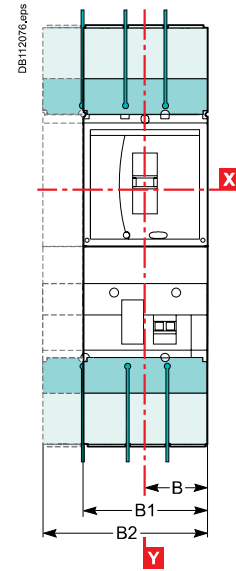

Mounting

On backplate

NSX100 to 250

3P

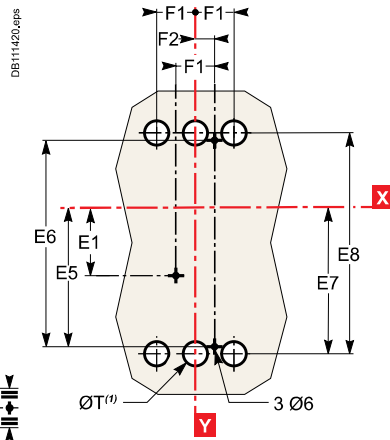
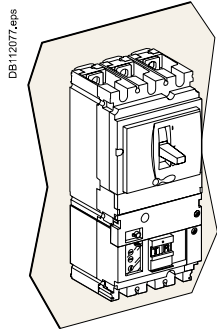

NSX400/630 (2)

3P

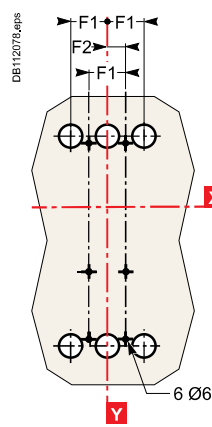

NSX100 to 630 (2)

4P

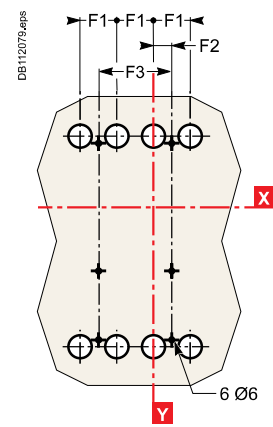

(2) For 630 A only:

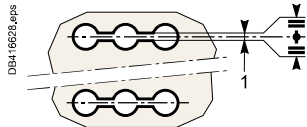

(1) The ØT holes are required for rear connection only.
For two-pole circuit breakers, the middle holes are not required.

On rails

3P

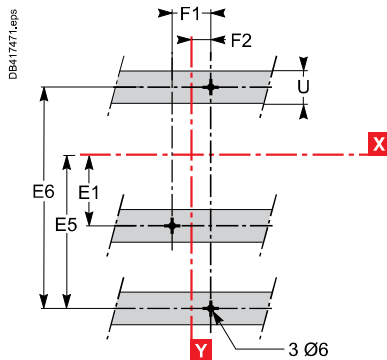
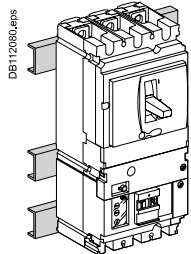

3P

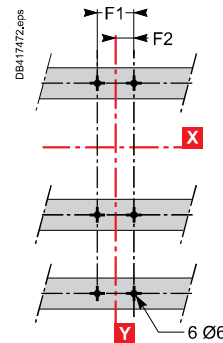

4P

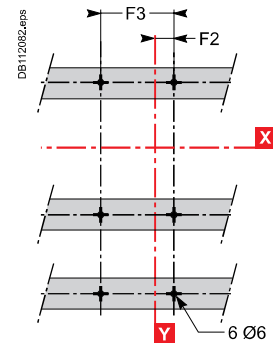

Type	A	A1	A2	A3	A4	A5	A6	A7	A8	A9	B	B1	B2	C1	C2	C3	E1
NSX100/160/250	80.5	161	94	145	178.5	155.5	236	169	220	253.5	52.5	105	140	81	86	126	62.5
NSX400/630	127.5	255	142.5	200	237	227.5	355	242.5	300	337	70	140	185	105	110	168	100
Type	E2	E3	E4	E5	E6	E7	E8	F1	F2	F3	G1	G2	G3	G4	G5	ØT	U

Dimensions

2/3P

4P

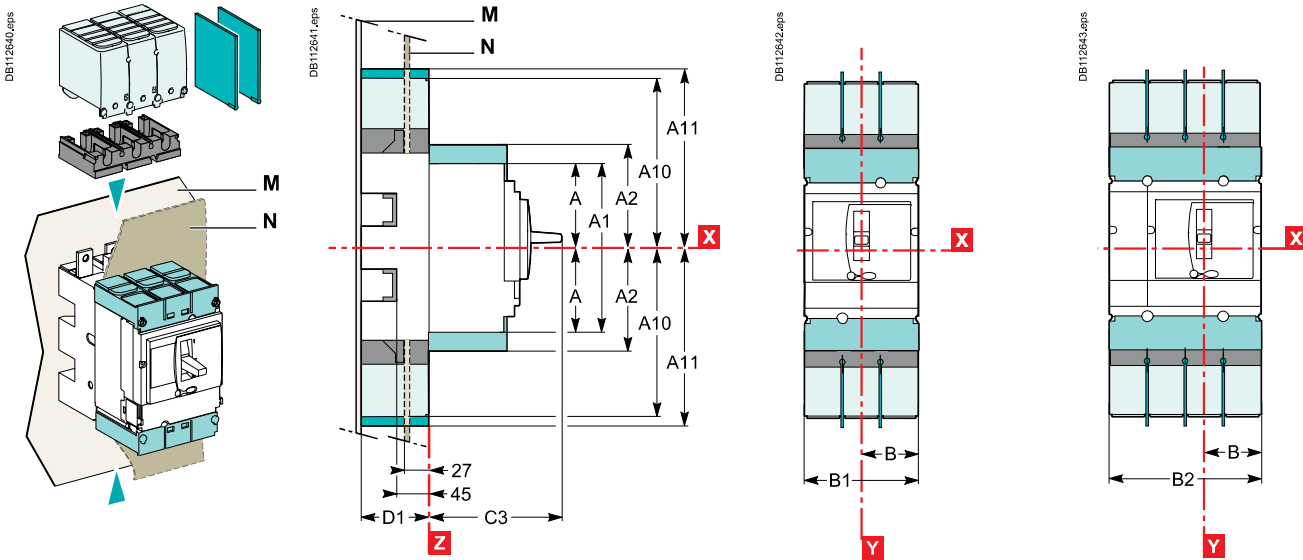

Interphase barriers for base.
 Short terminal shields on circuit breaker.

Long terminal shields (also available for NSX400/630 spreaders with 52.5 mm pitch: B1 = 157.5 mm, B2 = 210 mm).
 Adapter for base, required to mount long terminal shields or interphase barriers.

Mounting

Through front panel (N)

2/3P

3P

4P

NSX100 to 250

NSX400/630

NSX100 to 630

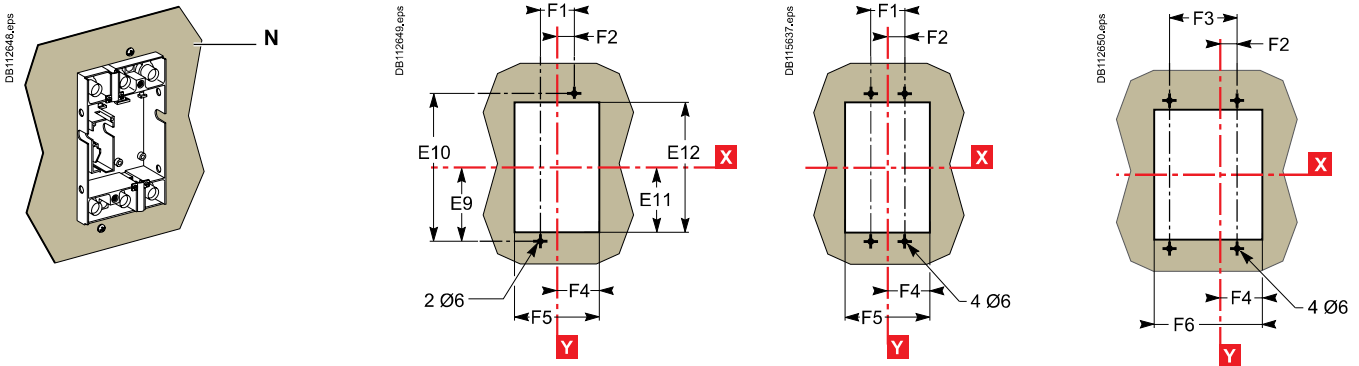

On backplate (M) **2/3P** **4P**

Front connection (an insulating screen is supplied with the base and must be fitted between the base and the backplate)

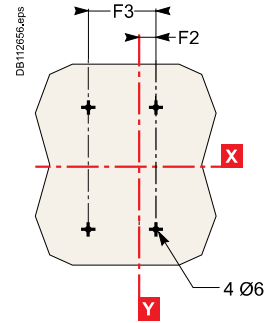
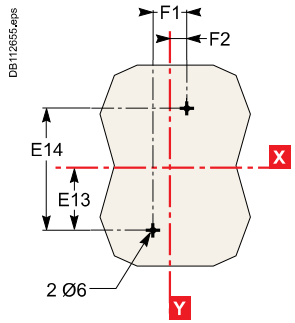
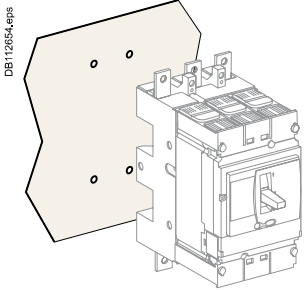

Connection by exterior-mounted rear connectors

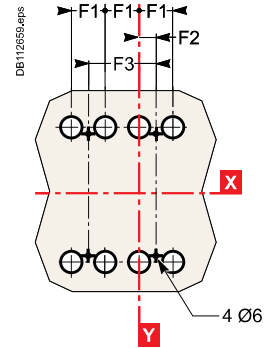
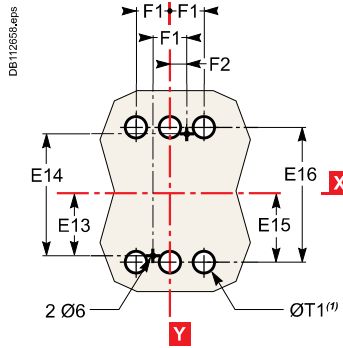
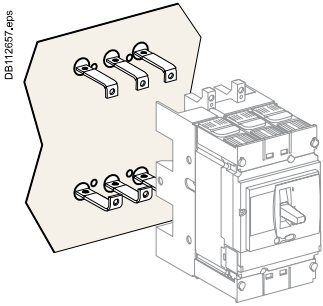

(1) The ØT1 holes are required for rear connection only (for two-pole circuit breakers, the middle holes are not required).

Connection by interior-mounted rear connectors

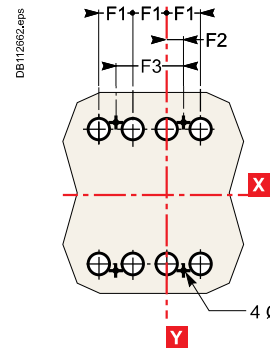
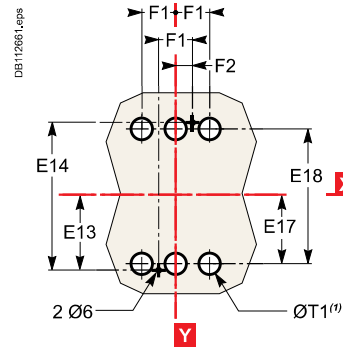
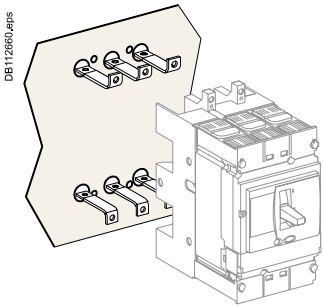

(1) The ØT1 holes are required for rear connection only (for two-pole circuit breakers, the middle holes are not required).

On rails **2/3P** **4P**

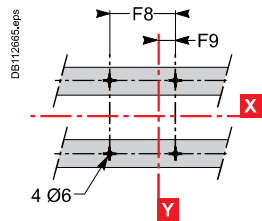
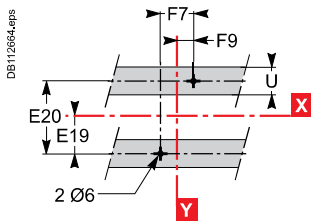
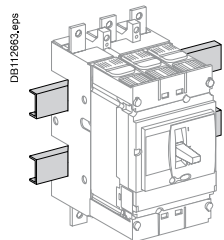

Type	A	A1	A2	A10	A11	B	B1	B2	C3	D1	E9	E10	E11	E12	E13	E14	E15
NSX100/160/250	80.5	161	94	175	210	52.5	105	140	126	75	95	190	87	174	77.5	155	79
NSX400/630	127.5	255	142.5	244	281	70	140	185	168	100	150	300	137	274	125	250	126
Type	E16	E17	E18	E19	E20	F1	F2	F3	F4	F5	F6	F7	F8	F9	ØT1	U	
NSX100/160/250	158	61	122	37.5	75	35	17.5	70	54.5	109	144	70	105	35	24	≤ 32	

Dimensions and mounting

Compact NSX100 to 630 withdrawable version

Dimensions

2/3P

4P

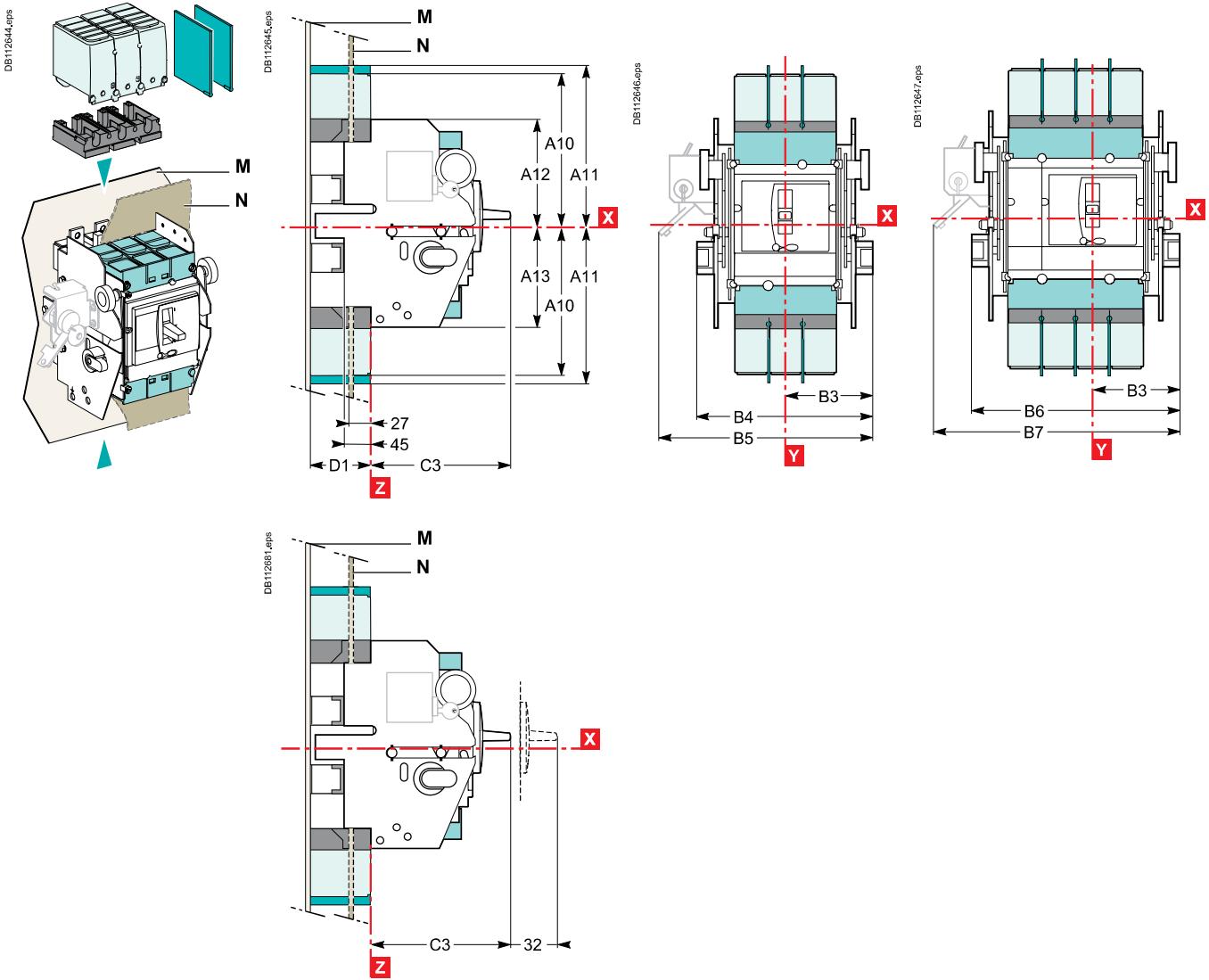

- Interphase barriers for base.
- Short terminal shields on circuit breaker.
- Long terminal shields.
- Adapter for base, required to mount long terminal shields or interphase barriers.

Mounting

Through front panel (N)

2/3P

NSX100 to 250

3P

NSX400/630

4P

NSX100 to 630

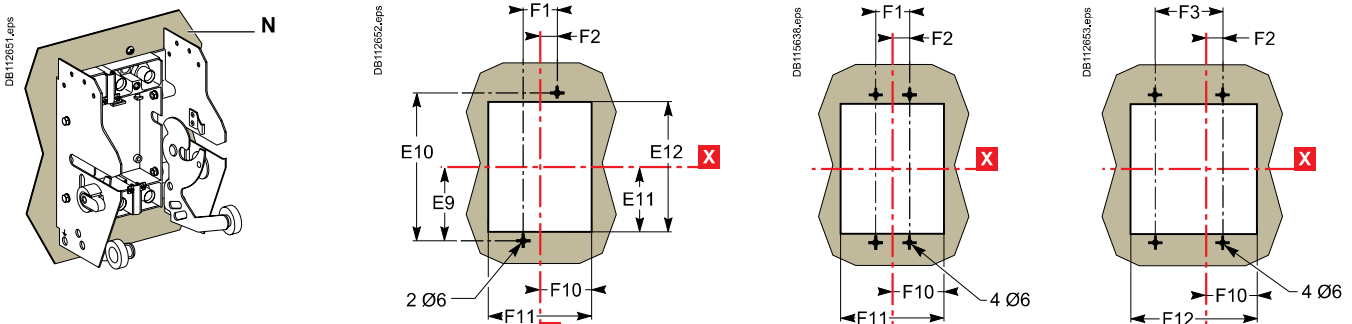

On backplate (M)

2/3P

4P

Front connection (an insulating screen is supplied with the base and must be fitted between the base and the backplate)

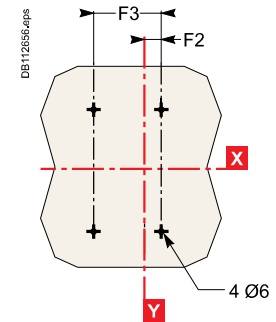
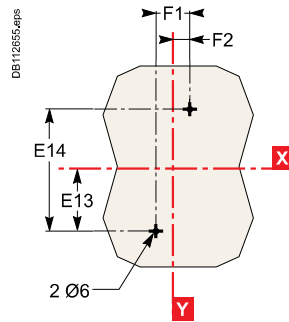
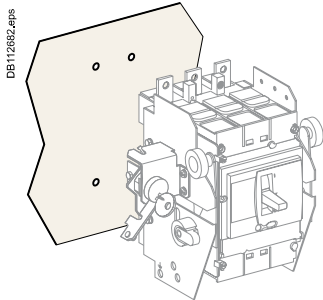

Connection by exterior-mounted rear connectors

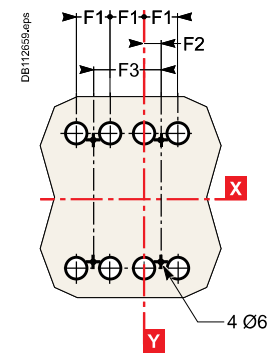
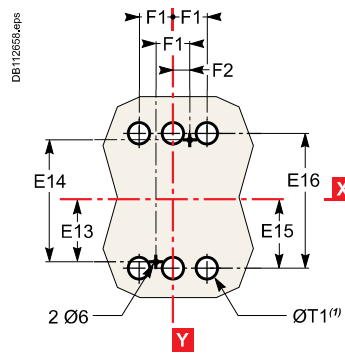
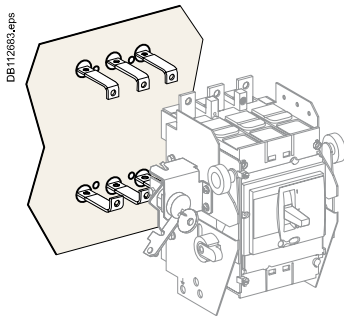

(1) The ØT1 holes are required for rear connection only (for two-pole circuit breakers, the middle holes are not required).

Connection by interior-mounted rear connectors

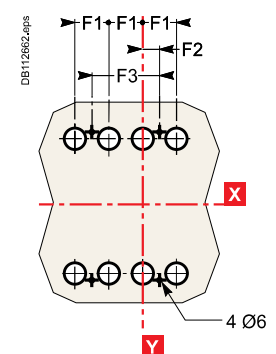
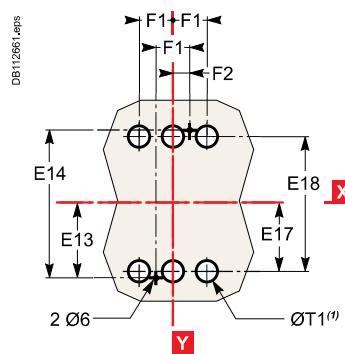
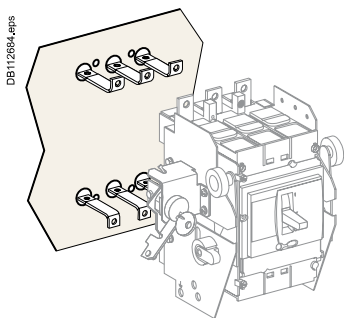

(1) The ØT1 holes are required for rear connection only (for two-pole circuit breakers, the middle holes are not required).

On rails

2/3P

4P

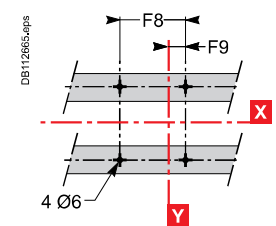
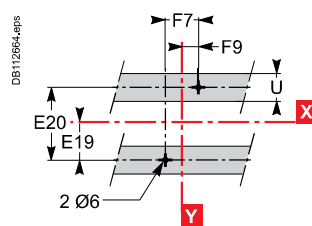
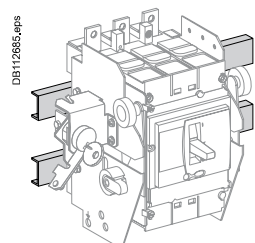

Type	A10	A11	A12	A13	B3	B4	B5	B6	B7	C3	D1	E9	E10	E11	E12	E13	E14
Type	E15	E16	E17	E18	E19	E20	F1	F2	F3	F7	F8	F9	F10	F11	F12	ØT1	U
NSX100/160/250	175	210	106.5	103.5	92.5	185	216	220	251	126	75	95	190	87	174	77.5	155
NSX400/630	244	281	140	140	110	220	250	265	295	168	100	150	300	137	274	125	250
NSX100/160/250	79	158	61	122	37.5	75	35	17.5	70	70	105	35	74	148	183	24	≤ 32

Dimensions and mounting

Vigicompact NSX100 to 630 plug-in and withdrawable versions

Dimensions - plug-in version

NSX100 to 250

NSX400/630

3/4P

3/4P

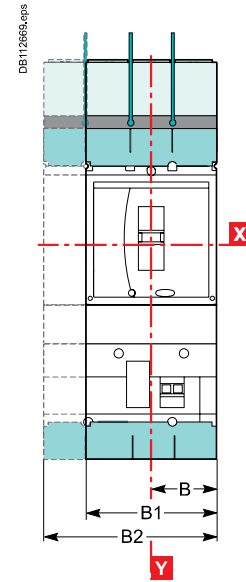
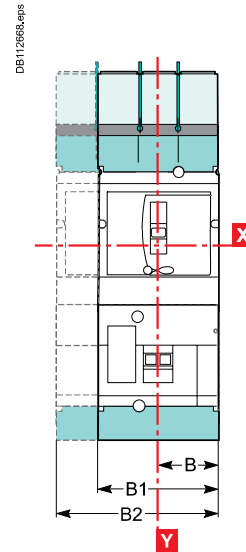
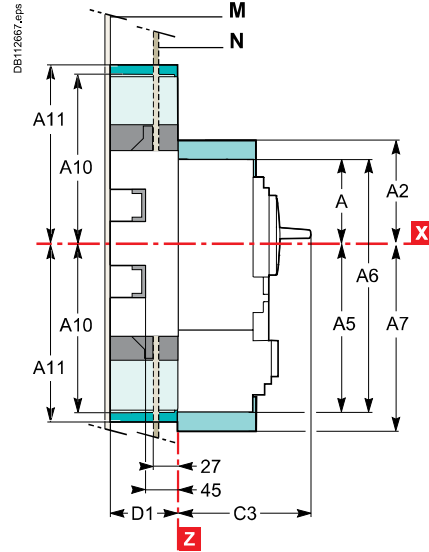
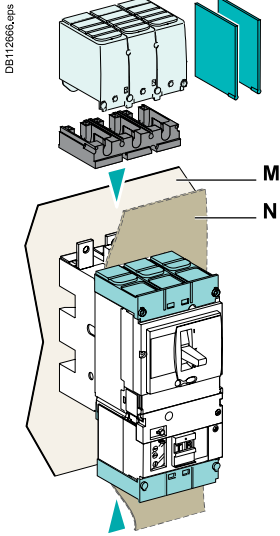

Interphase barriers for base.

Short terminal shields on circuit breaker.

Long terminal shields (also available for NSX400/630 spreaders with 52.5 mm pitch: B1 = 157.5 mm, B2 = 210 mm).

Adapter for base, required to mount long terminal shields or interphase barriers.

Dimensions - withdrawable version

NSX100 to 630

3P

4P

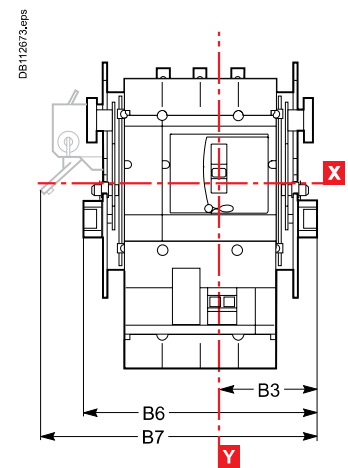
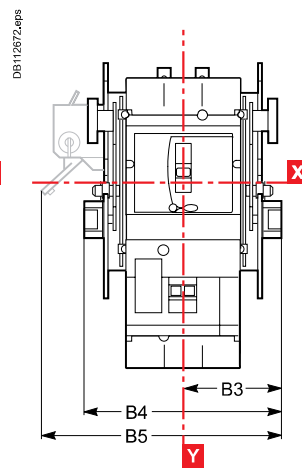
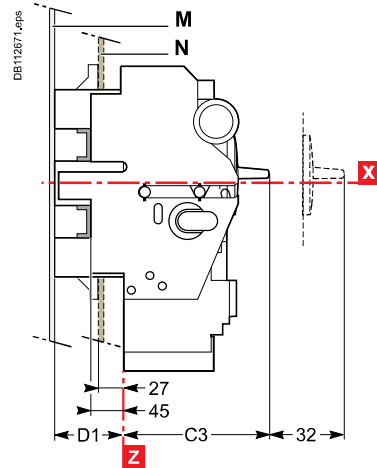
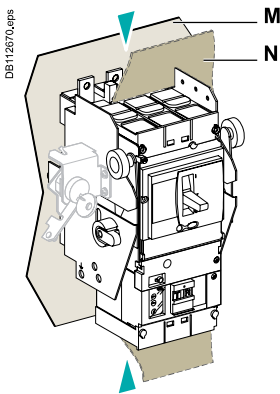

Mounting

Through front panel (N)

See Compact NSX100 to 630 plug-in version, [page C-6](#), or withdrawable version, [page C-8](#)

On backplate (M)

See Compact NSX100 to 630 plug-in version, [page C-7](#), or withdrawable version, [page C-9](#)

On rails

See Compact NSX100 to 630 plug-in version, [page C-7](#), or withdrawable version, [page C-9](#)

Type	A	A2	A5	A6	A7	A10	A11	B	B1	B2	B3	B4	B5	B6	B7	C3	D1
NSX100/160/250	80.5	94	155.5	236	169	175	210	52.5	105	140	92.5	185	216	220	251	126	75

Visu function for Compact NSX100 to 250 fixed version

Dimensions - combination with Compact INV100 to 250 3P 4P

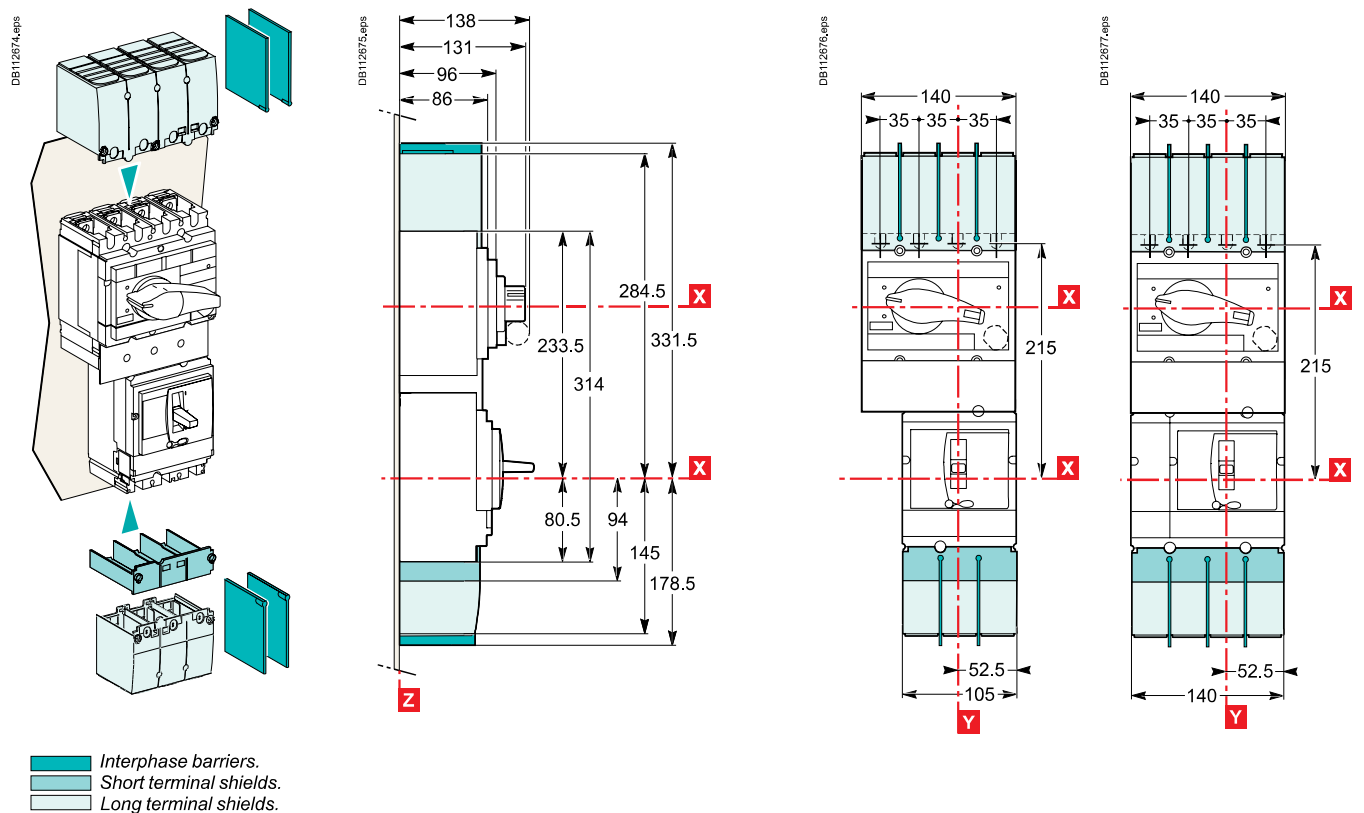

Mounting 3P 4P

On rails or backplate

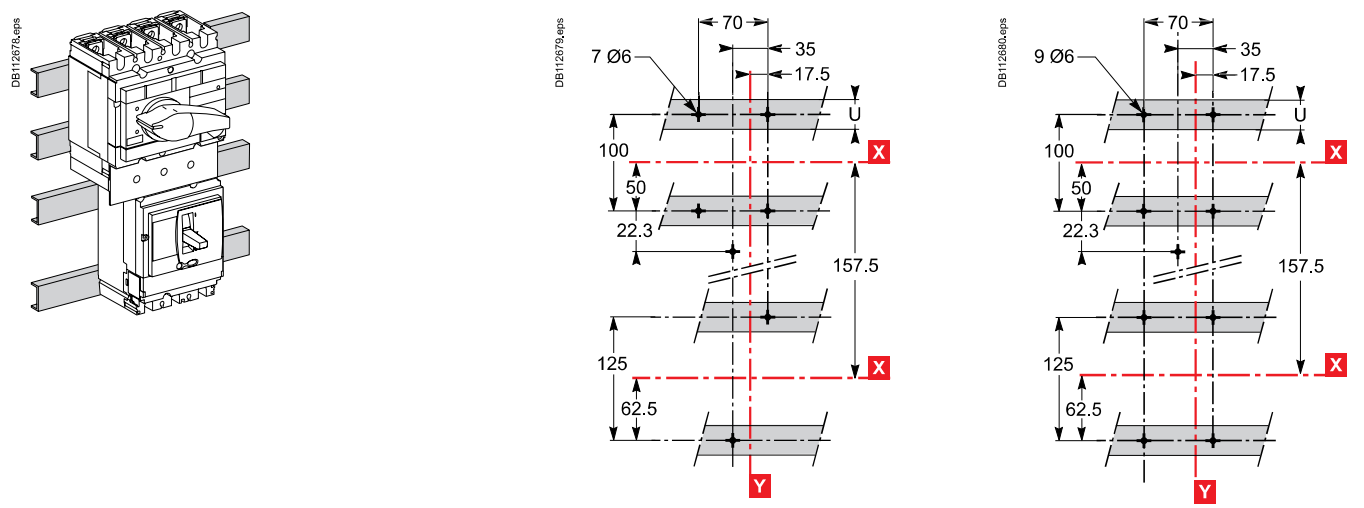

Dimensions and mounting

Visu function for Compact NSX400/630 fixed version

Dimensions - combination with Compact INV400 to 630

3P

4P

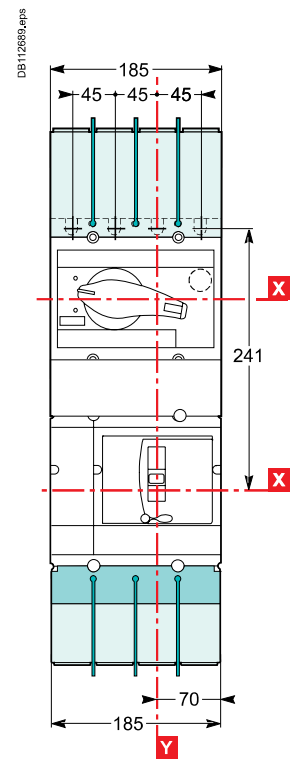
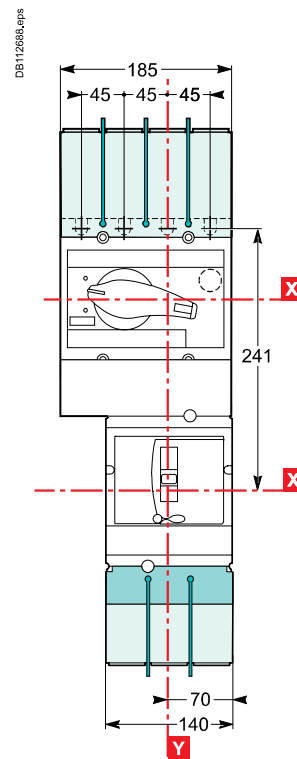
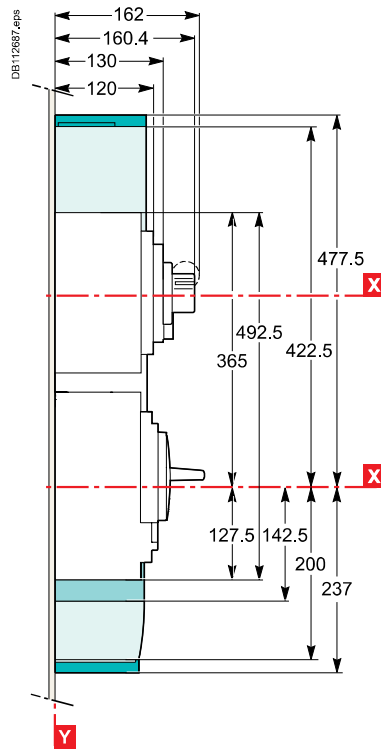
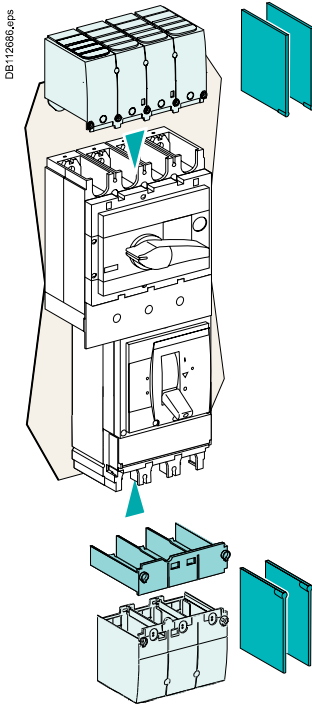

- Interphase barriers for base.
- Short terminal shields.
- Long terminal shields.

Mounting

3P

4P

On rails or backplate

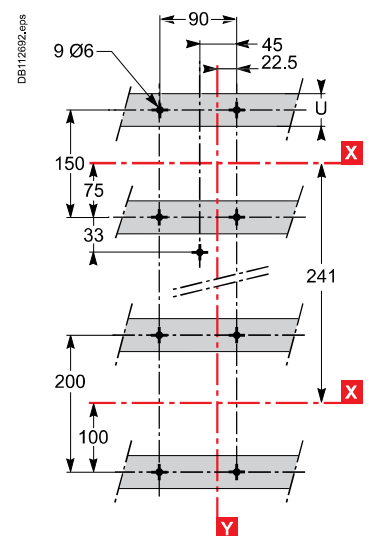
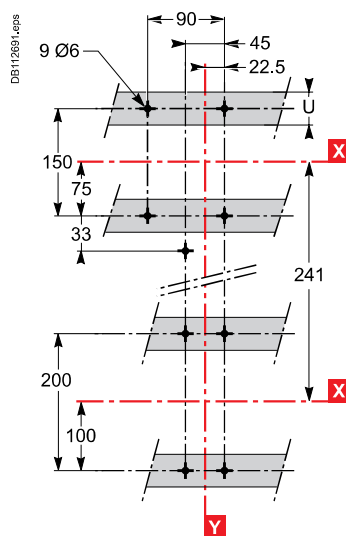
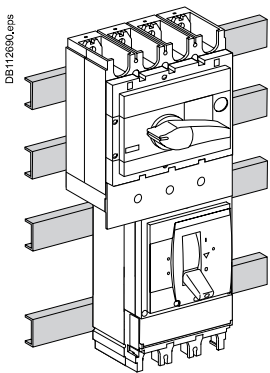

Motor mechanism module for Compact NSX100 to 630

Dimensions

3P

4P

Fixed circuit breaker

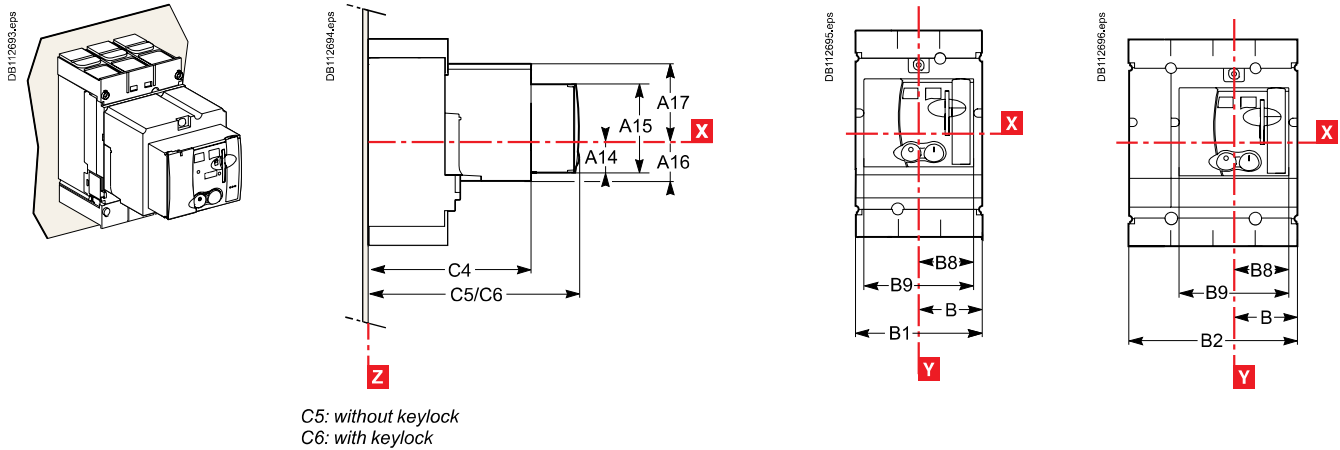

Plug-in circuit breaker

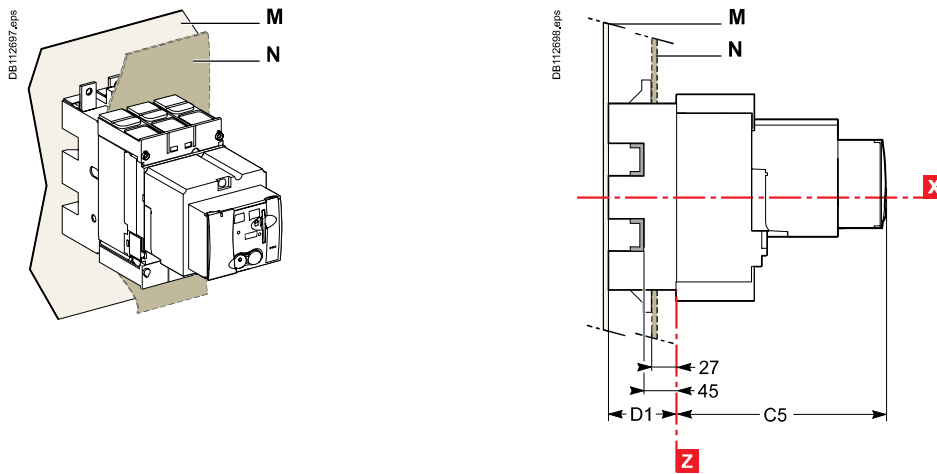

Withdrawable circuit breaker

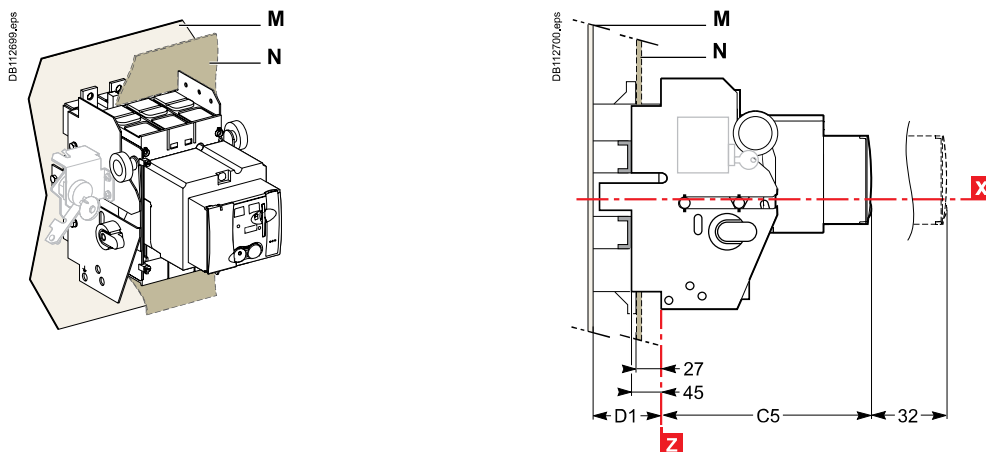

Type	A14	A15	A16	A17	B	B1	B2	B8	B9	C4	C5	C6	D1
NSX100/160/250	27.5	73	34.5	62.5	52.5	105	140	45.5	91	143	182	209.5	75

Dimensions and mounting

Direct rotary handle for Compact and Vigicompact NSX100 to 630

Dimensions

3P

4P

Fixed circuit breaker

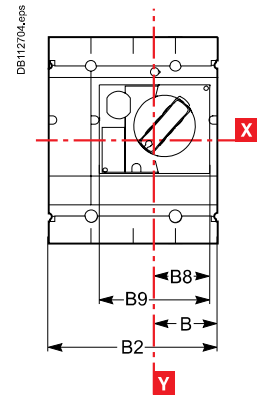
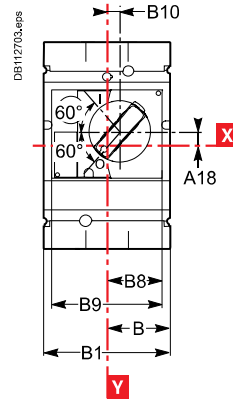
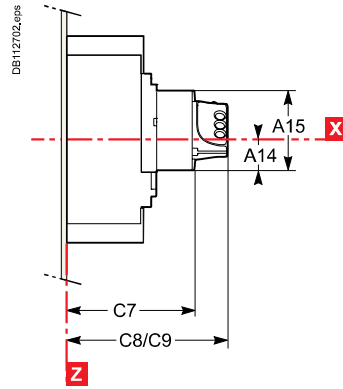
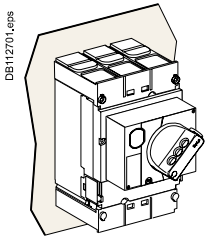

C8: without keylock
C9: with keylock

Plug-in circuit breaker

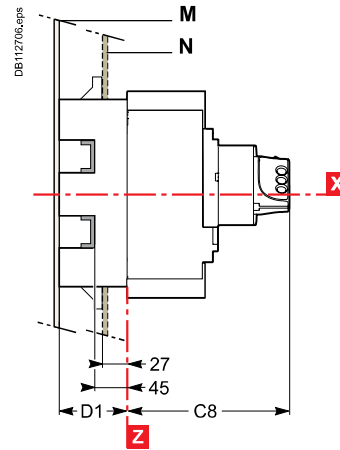
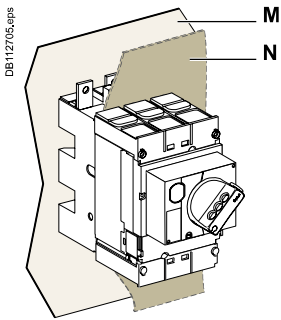

Withdrawable circuit breaker

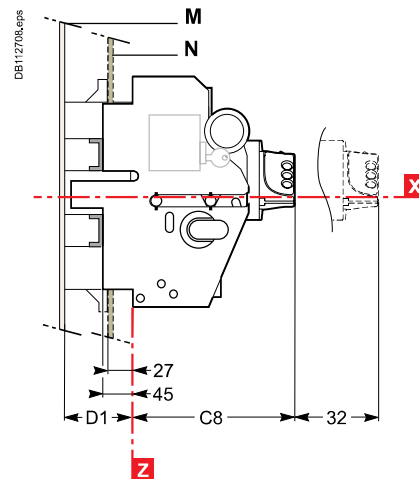
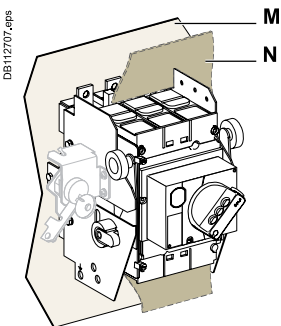

Type	A14	A15	A18	B	B1	B2	B8	B9	B10	C7	C8	C9	D1
NSX100/160/250	27.5	73	9	52.5	105	140	45.5	91	9.25	121	155	164	75

MCC and CNOMO type direct rotary handles for Compact NSX100 to 630 fixed version

Dimensions

MCC type direct rotary handle

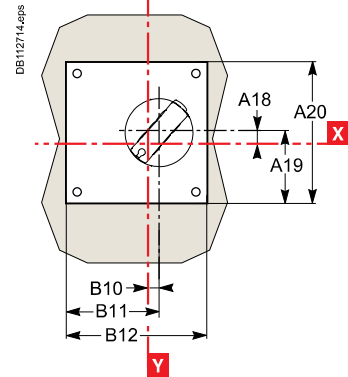
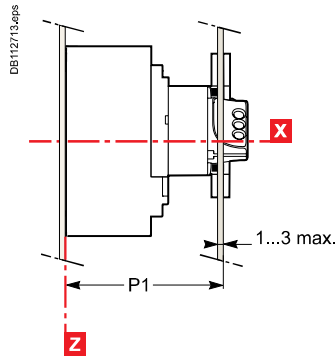
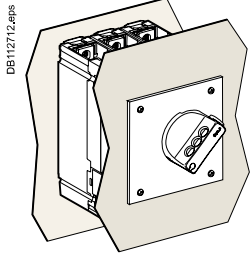

CNOMO type direct rotary handle

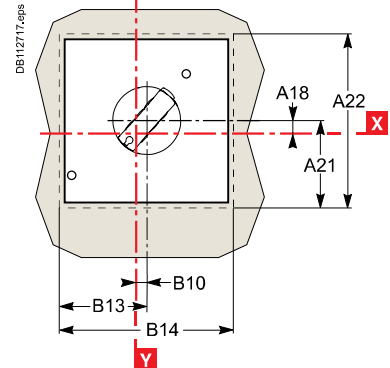
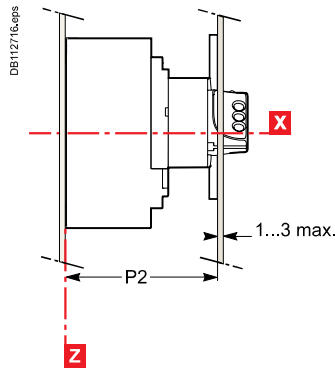
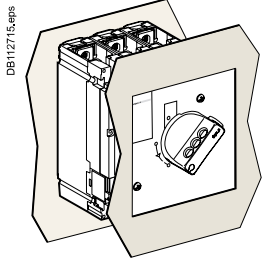

Front-panel cutout

NSX100 to 250

NSX400/630

MCC type direct rotary handle

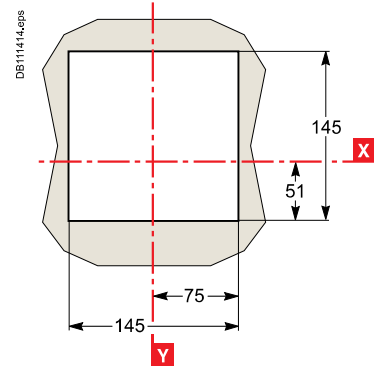
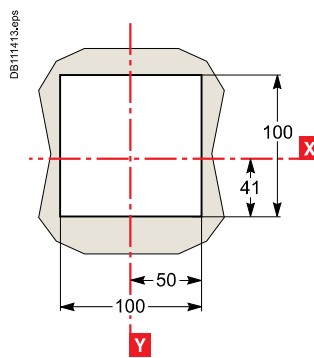
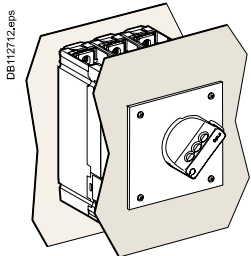

CNOMO type direct rotary handle

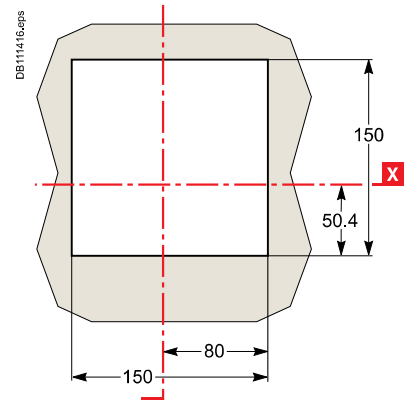
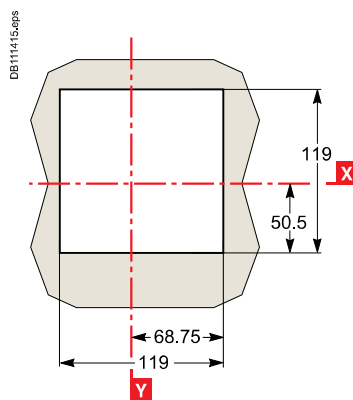
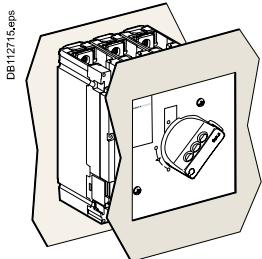

Type	A18	A19	A20	A21	A22	B10
NSX100/160/250	9	60	120	65	130	9.25
NSX400/630	24.6	83	160	82	164	5
Type	B11	B12	B13	B14	P1	P2
NSX100/160/250	69	120	65	130	125	135

Dimensions and mounting

Extended rotary handle for Compact NSX100 to 630

Dimensions

Fixed and plug-in circuit breakers

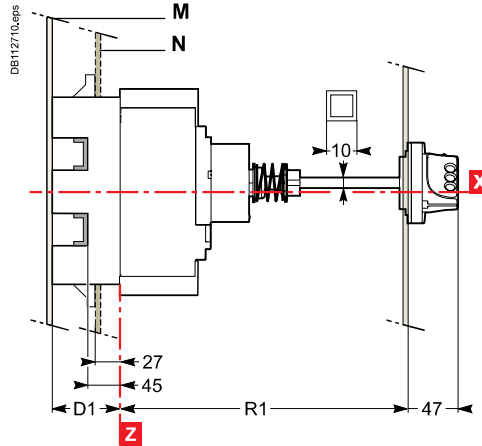
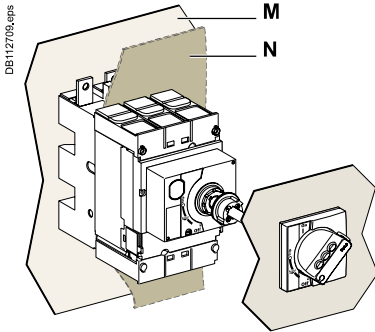

Cutout for shaft (mm)

Type	R1
NSX100/160/250	min. 171 max. 600
NSX400/630	min. 195 max. 600

Withdrawable circuit breaker

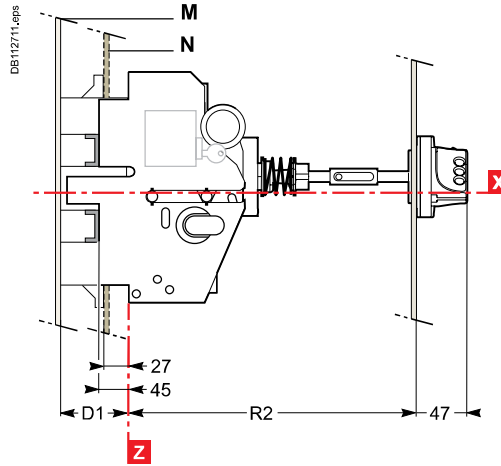
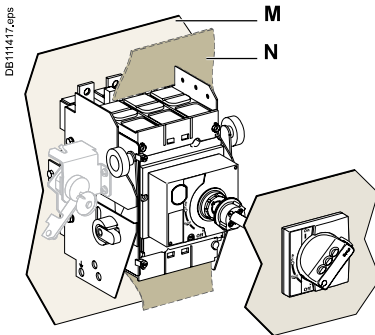

Cutout for shaft (mm)

Type	R2
NSX100/160/250	min. 248 max. 600
NSX400/630	min. 272 max. 600

Dimensions and front-panel cutout

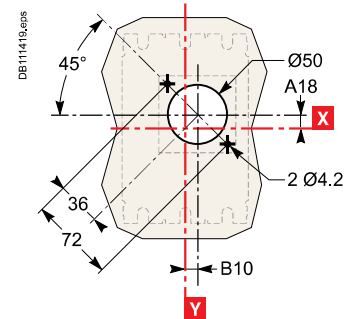
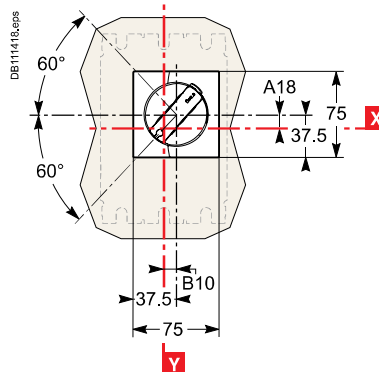

Type	A18	B10	D1
NSX100/160/250	9	9.25	75

Dimensions and mounting

Indication and measurement modules for Compact NSX100 to 630 fixed version

Dimensions

Circuit breaker with ammeter module

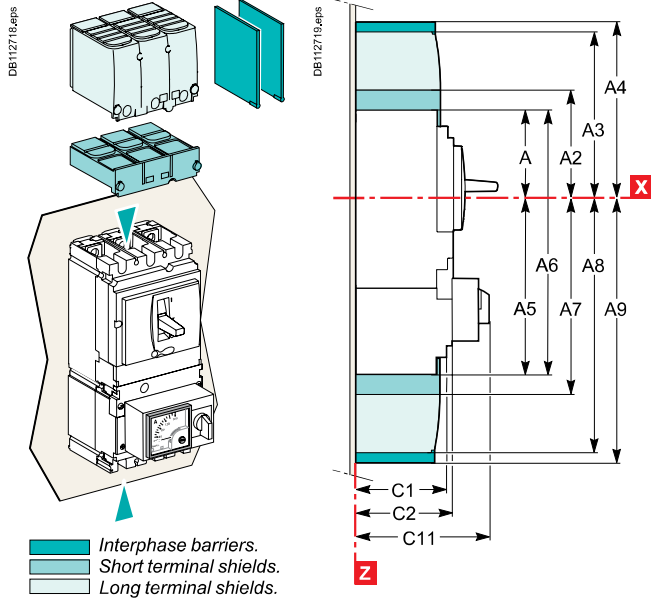

Circuit breaker with current-transformer module

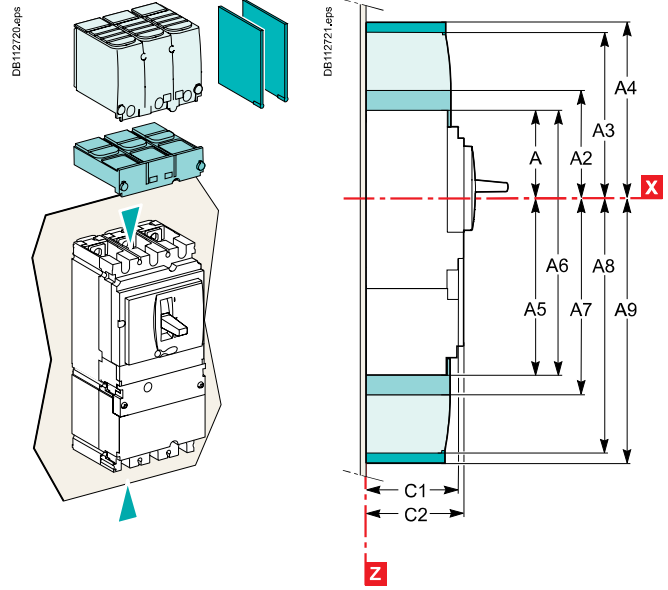

Mounting

On backplate

NSX100 to 250

2/3P

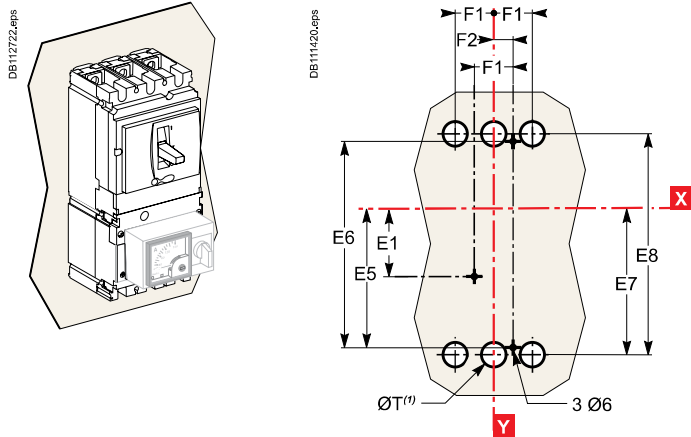

NSX400/630

3P

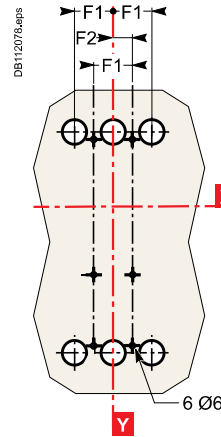

NSX100 to 630

4P

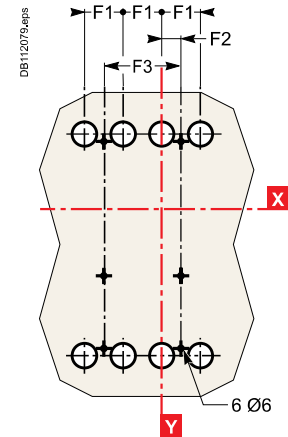

(1) The ØT holes are required for rear connection only.
 For two-pole circuit breakers, the middle holes are not required.

On rails

2/3P

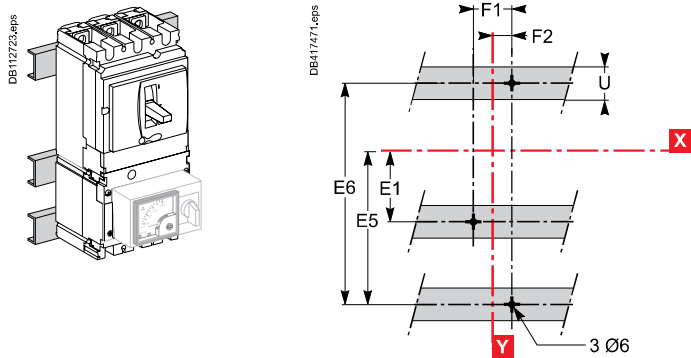

3P

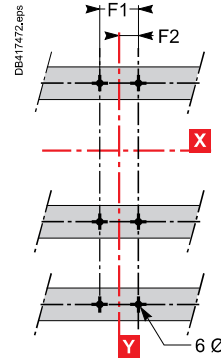

4P

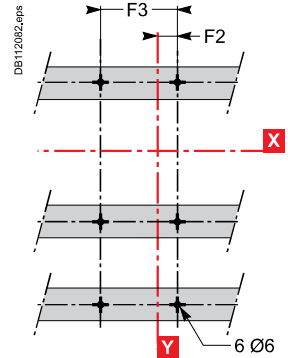

Type	A	A2	A3	A4	A5	A6	A7	A8	A9	C1	C2	C11	E1	E5	E6	E7	E8
NSX100/160/250	80.5	94	145	178.5	155.5	236	169	220	253.5	81	86	137	62.5	137.5	200	145	215
NSX400/630	127.5	142.5	200	237	227.5	355	242.5	300	337	95.5	110	162	100	200	300	213.5	327
Type	F1	F2	F3	ØT	U												

Dimensions and mounting

One-piece spreader for Compact NSX100 to 250 fixed version

Dimensions

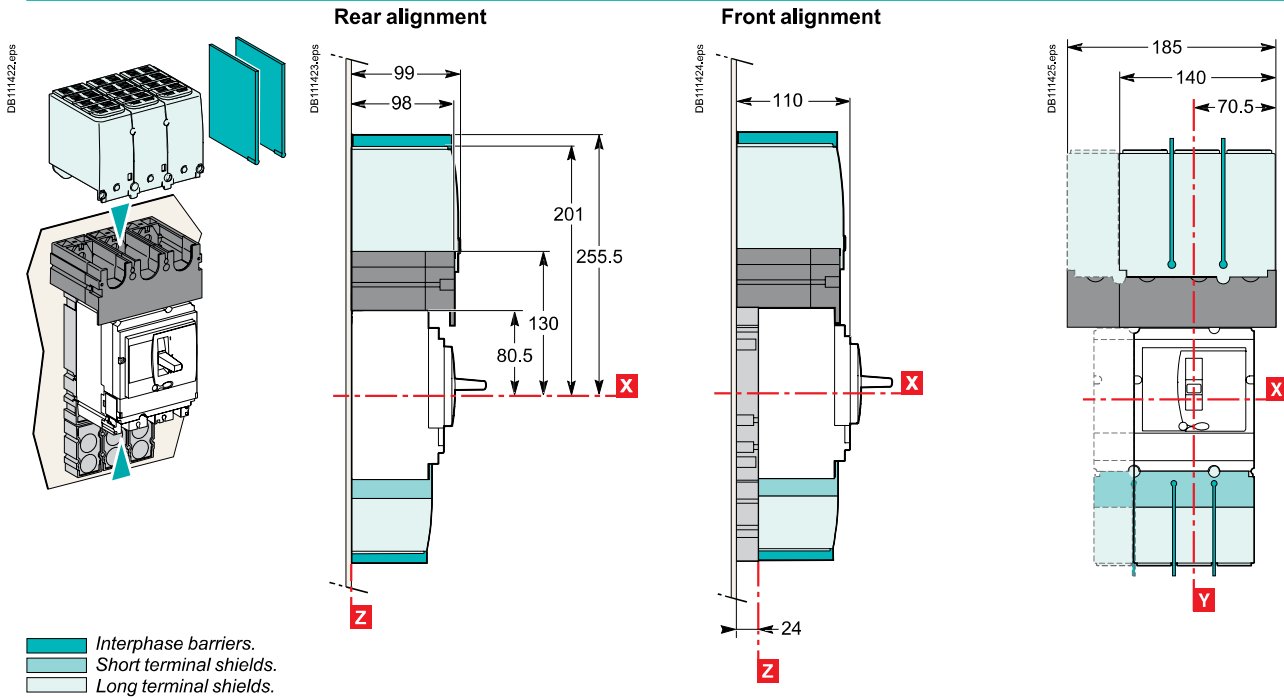

Mounting

Rear alignment

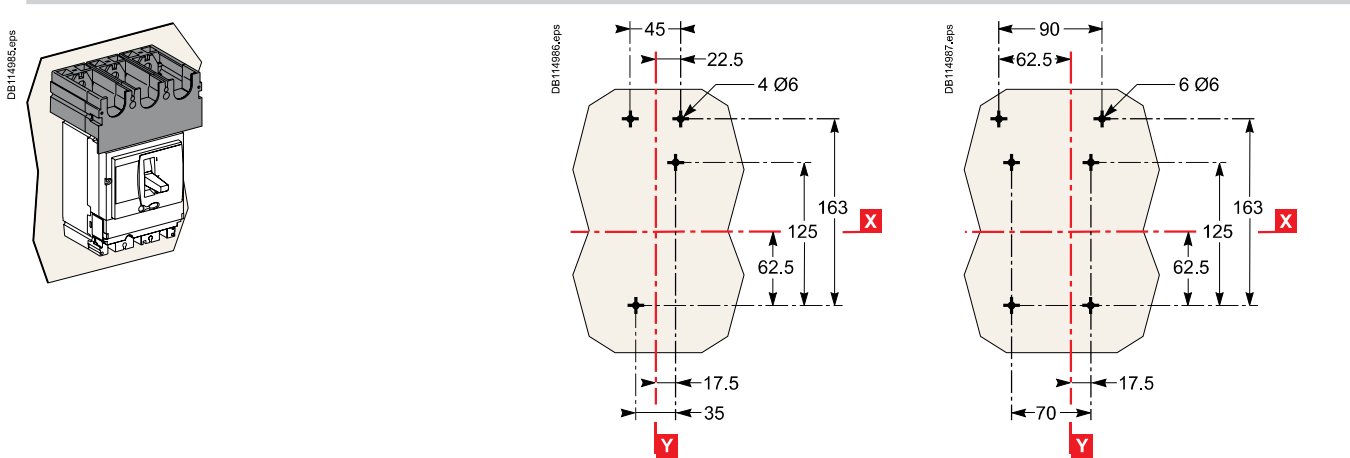

Front alignment

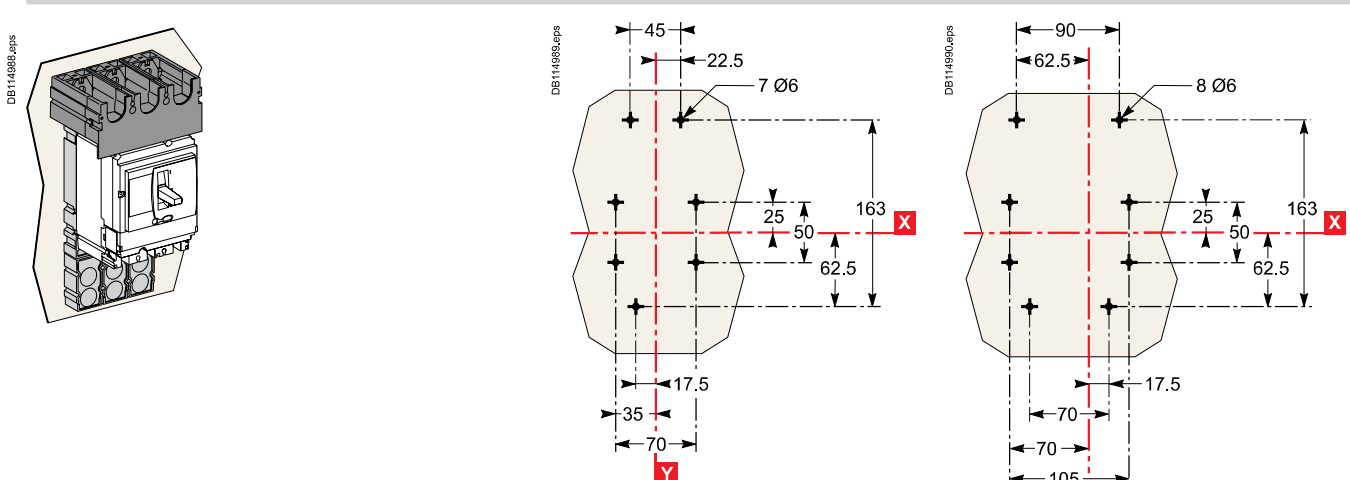

I/O (Input/Output) application module

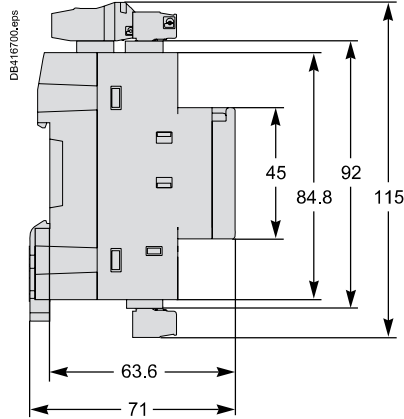
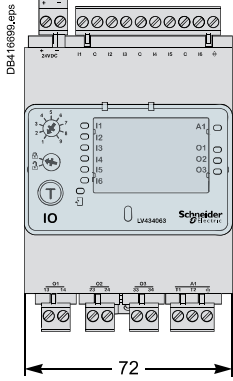

IFM - Modbus-SL interface

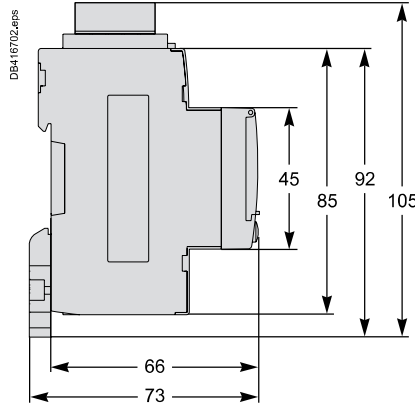
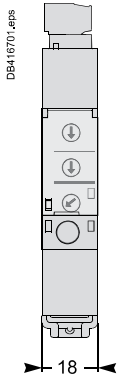

IFE - Ethernet interface

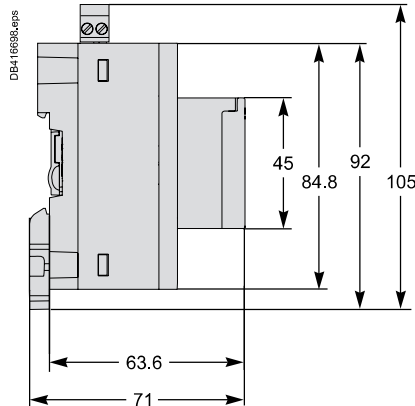
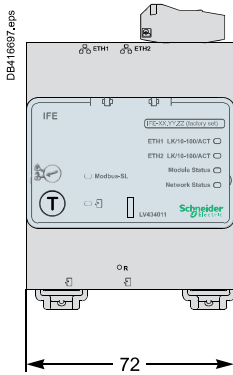

Com'X 200

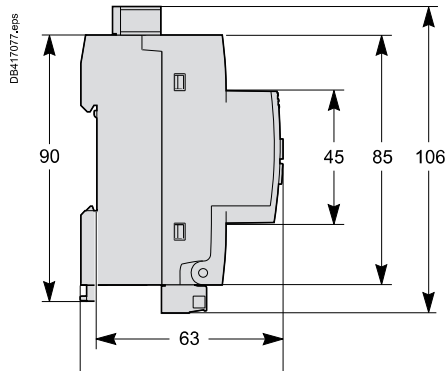
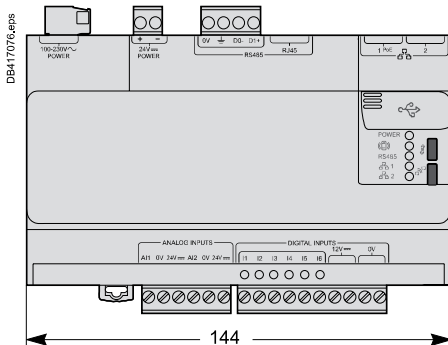

FDM121 switchboard display

Dimensions

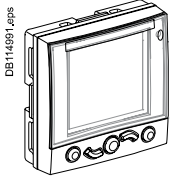

DB114951.eps

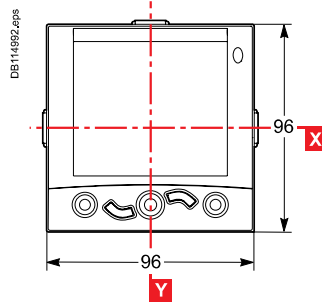

Mounting

Through panel

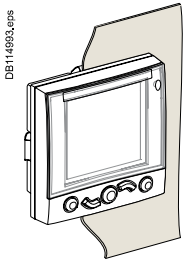

DB114993.eps

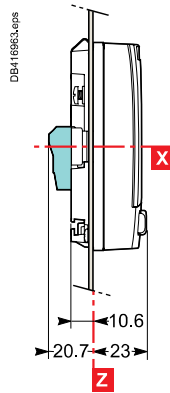

DB116583.eps

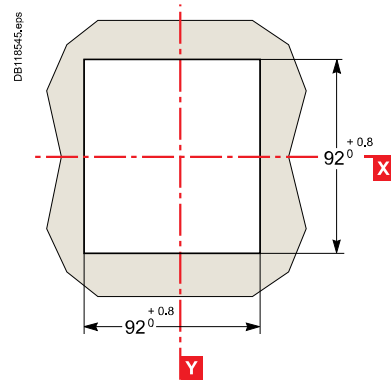

DB116545.eps

On panel

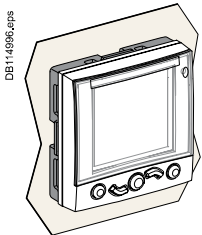

DB114996.eps

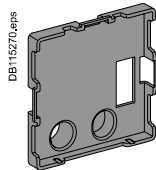

DB115270.eps

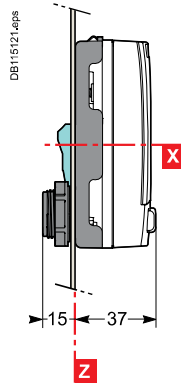

DB115121.eps

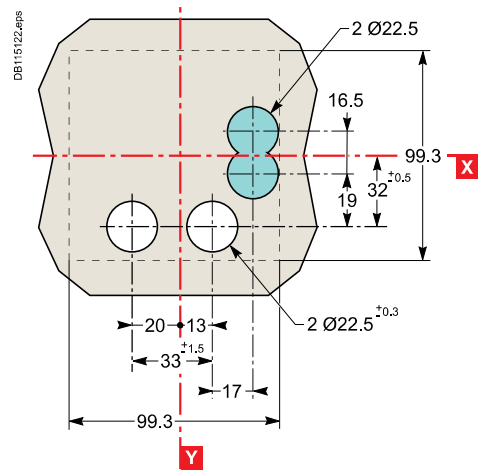

DB115122.eps

 Connector (optional).

Dimensions

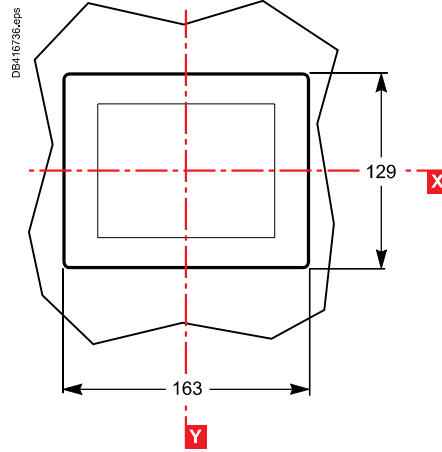
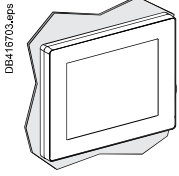

Mounting

On panel

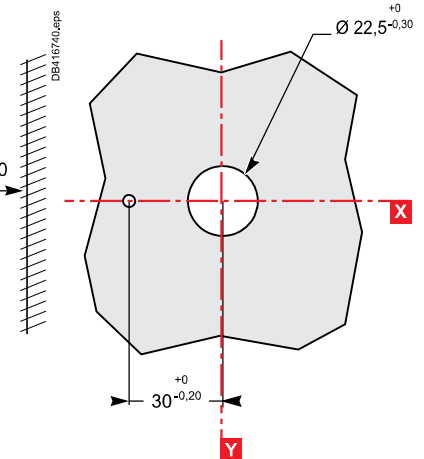
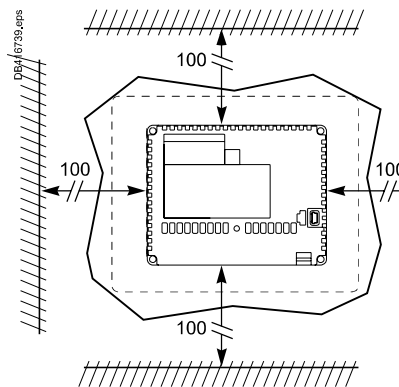
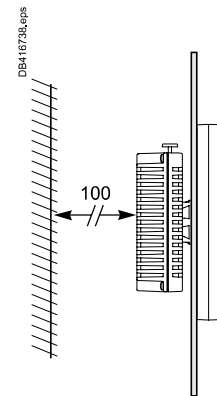
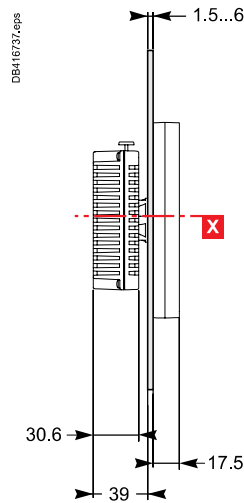
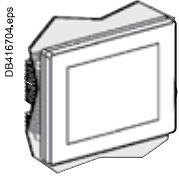

Front-panel accessories

Compact NSX100 to 630

IP30 front-panel escutcheons

For toggle, rotary handle or motor mechanism module

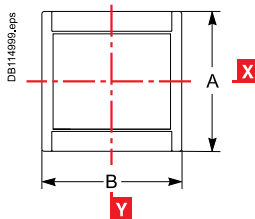
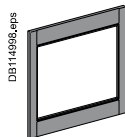
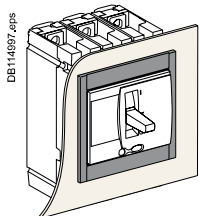

For toggle or rotary handle with access to trip unit

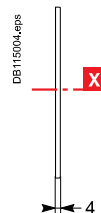
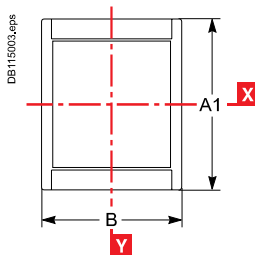
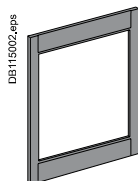
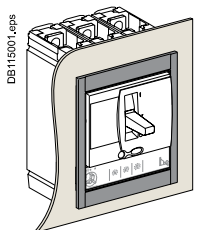

For Vigicompact

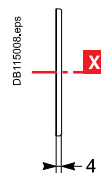
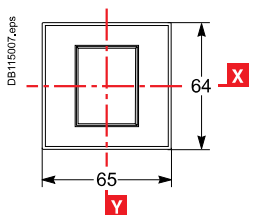
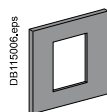
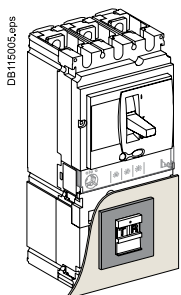

IP40 front-panel escutcheons

For toggle, rotary handle or motor mechanism module and protection collar

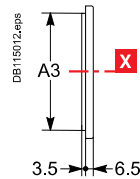
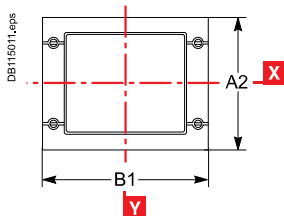
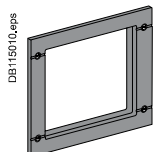
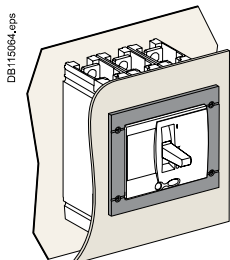

For Vigicompact with protection collar or ammeter module

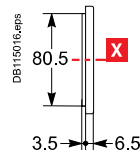
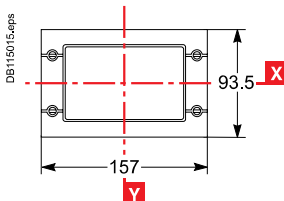
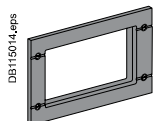
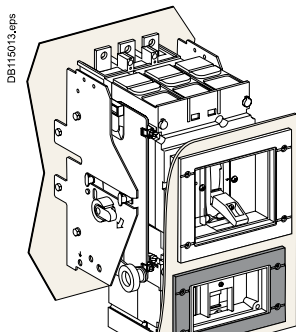

IP40 front-panel escutcheons (cont.)

For Vigicomact

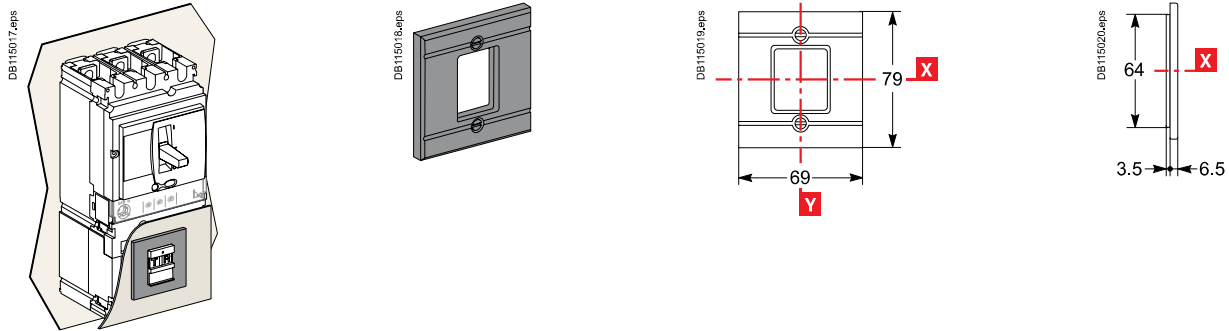

Protection collars for IP40 front-panel escutcheons

For toggle

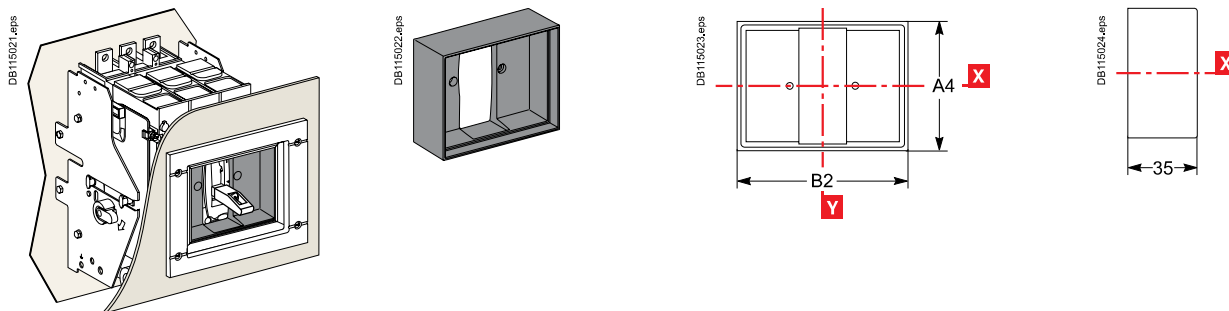

For Vigicomact

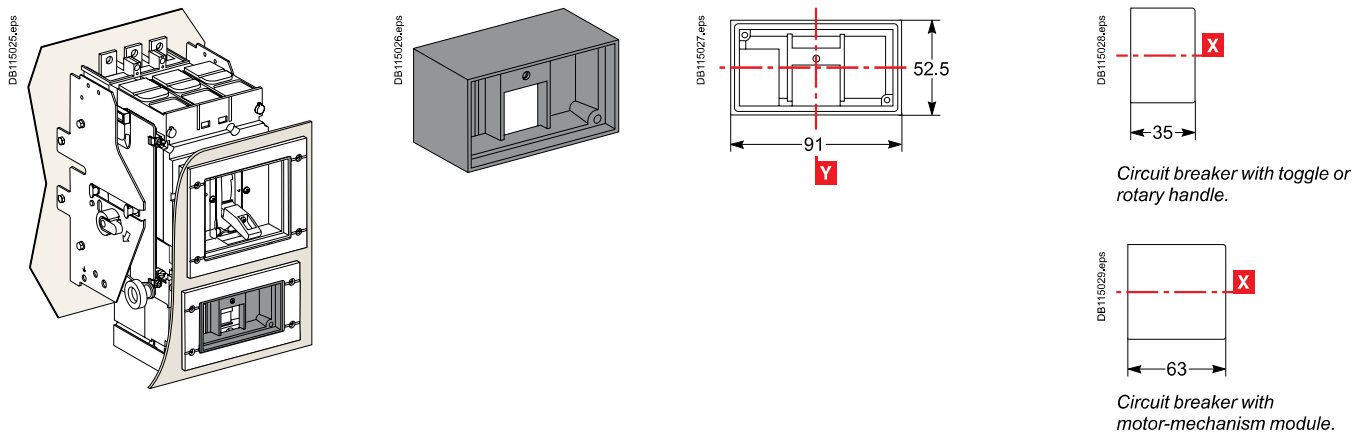

IP43 toggle cover

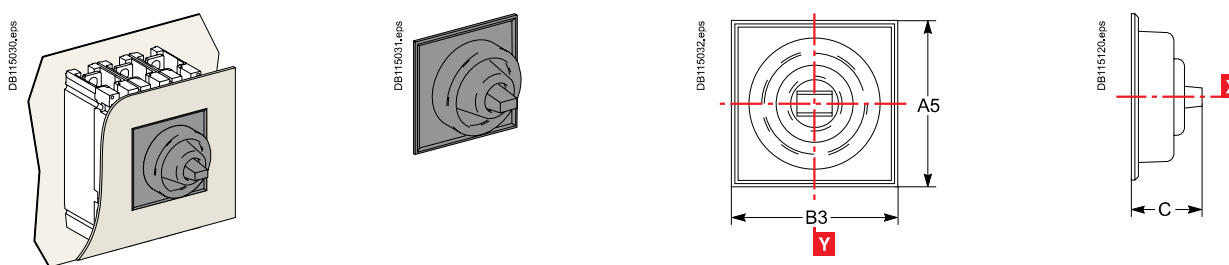

Type	A	A1	A2	A3	A4	A5	B	B1	B2	B3	C
NSX100/160/250	113	138	114	101	73	85	113	157	91	103	40

Front-panel cutouts

Compact NSX100 to 630 fixed version

Bare sheet metal

NSX100 to 250

NSX400/630

For toggle

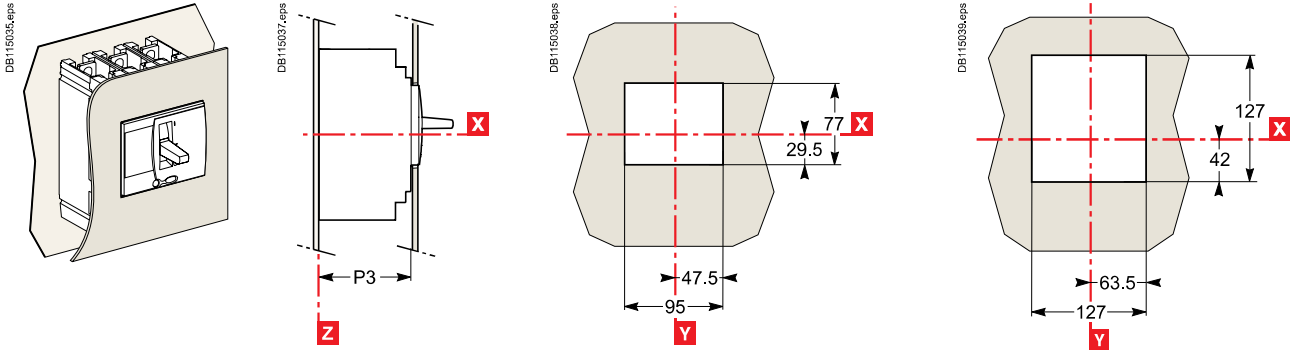

For toggle with access to trip unit

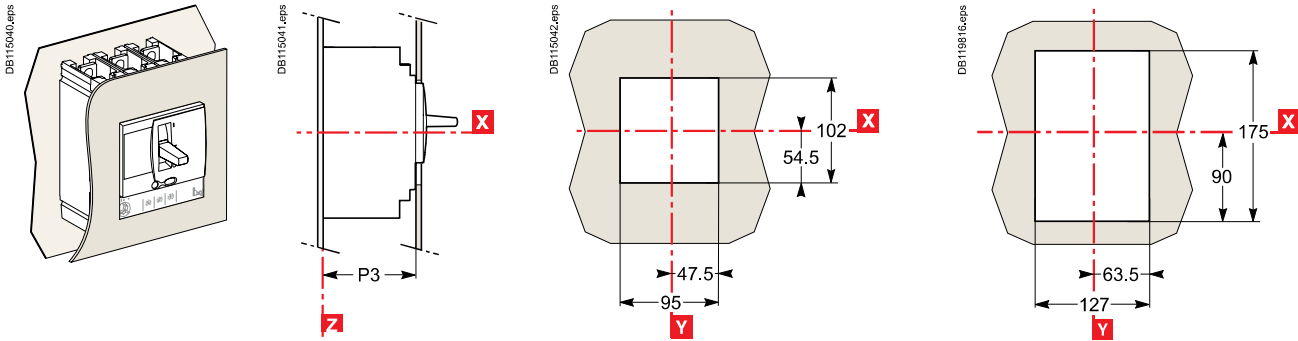

With IP30 front-panel escutcheon

NSX100 to 250

NSX400/630

For toggle

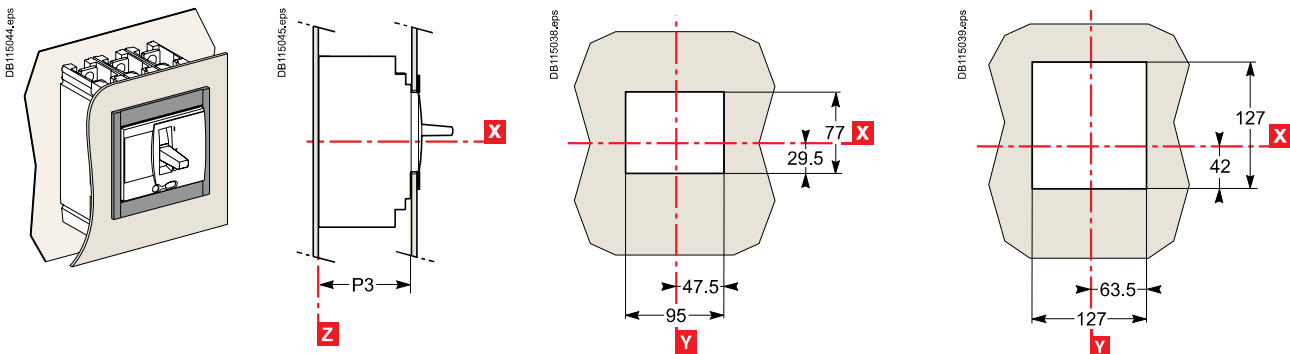

For toggle with access to trip unit

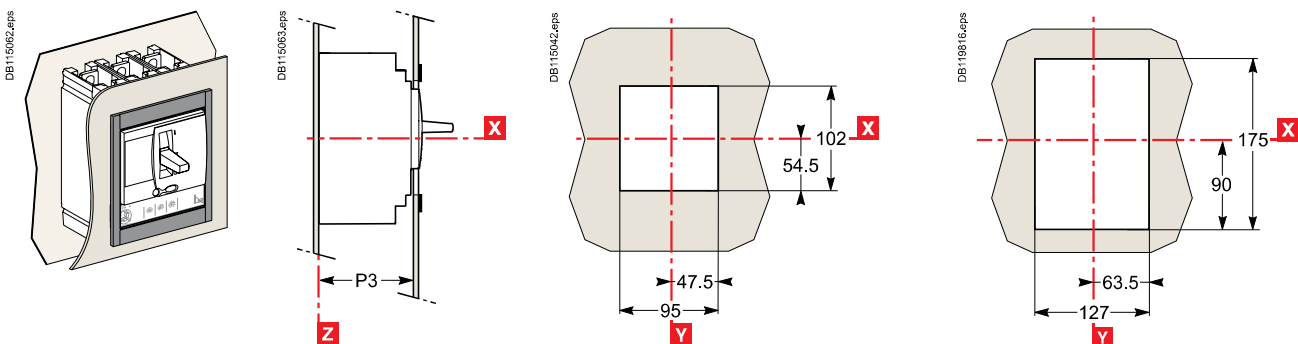

With IP40 front-panel escutcheon

NSX100 to 250

NSX400/630

For toggle

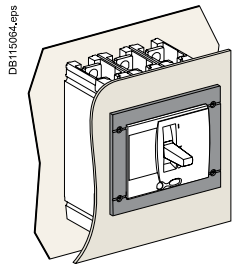

DB115064.dps

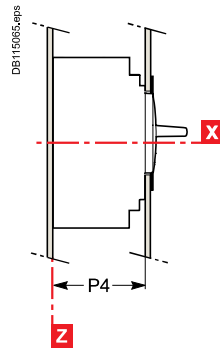

DB115065.dps

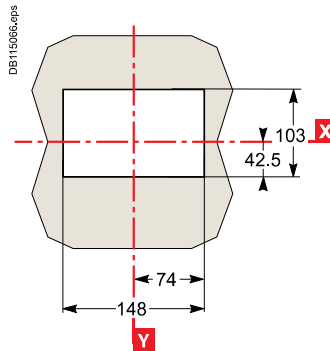

DB115066.dps

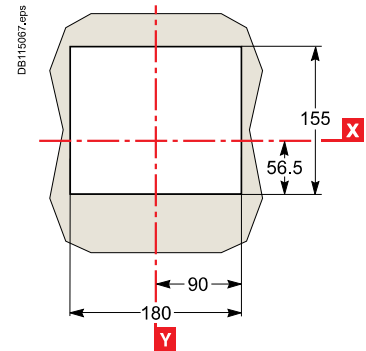

DB115067.dps

With IP43 toggle cover

NSX100 to 250

NSX400/630

For toggle

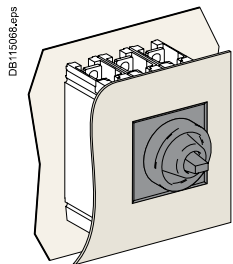

DB115068.dps

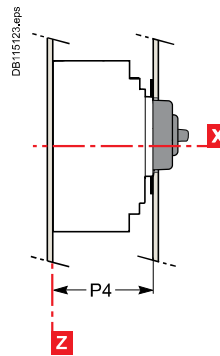

DB115123.dps

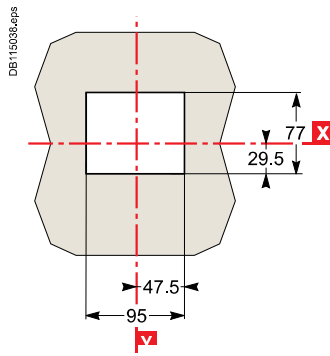

DB115038.dps

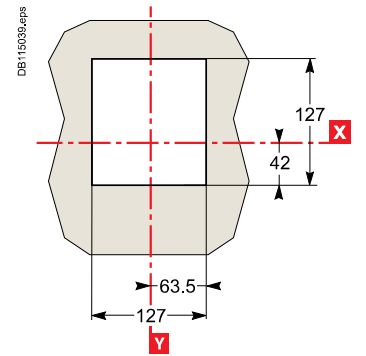

DB115039.dps

Type	P3	P4
NSX100/160/250	88	89

Note: door cutout dimensions are given for a device position in

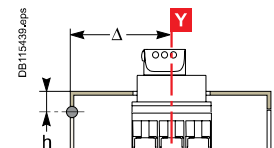

Front-panel cutouts

Vigicompact NSX100 to 630 fixed version

Bare sheet metal

NSX100 to 250

NSX400/630

For toggle

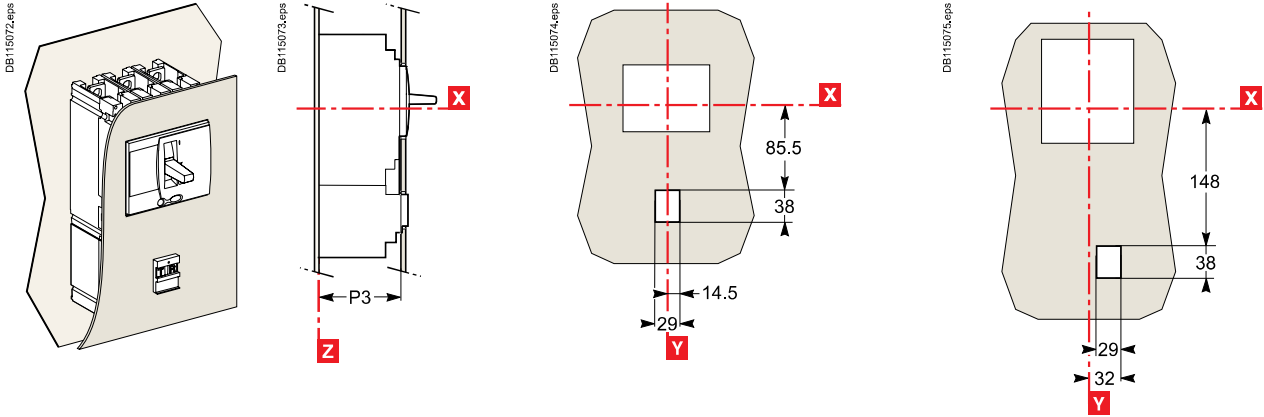

For toggle with access to trip unit

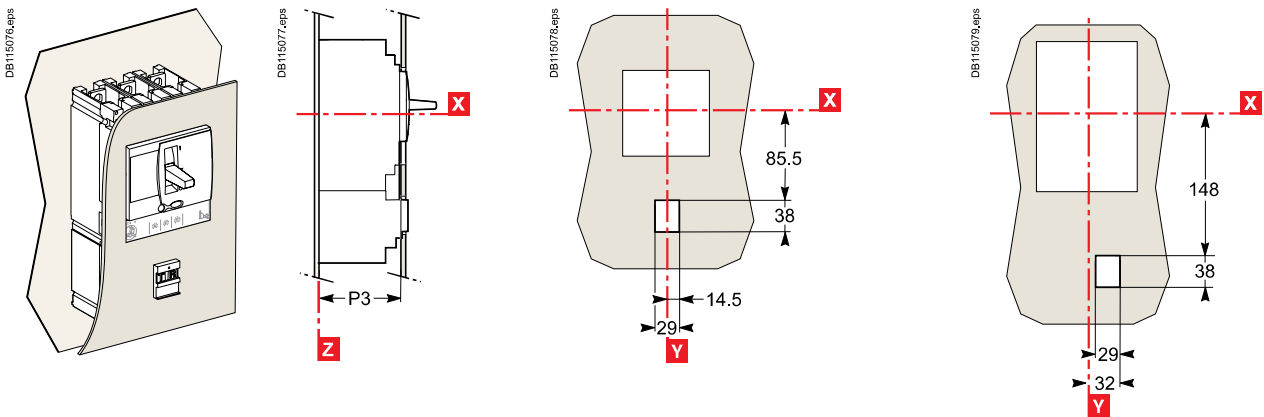

With IP30 front-panel escutcheon

NSX100 to 250

NSX400/630

For toggle

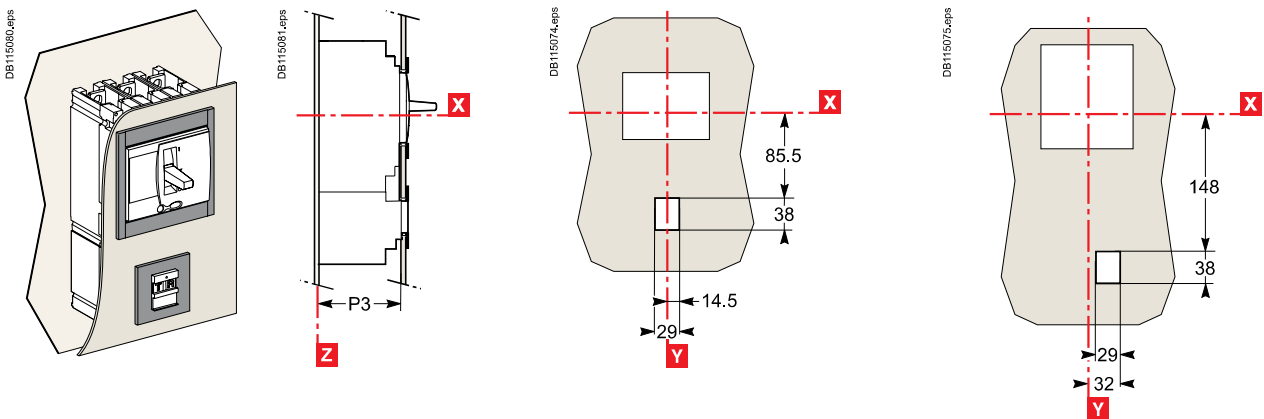

With IP30 front-panel escutcheon (cont.)

NSX100 to 250

NSX400/630

For toggle with access to trip unit

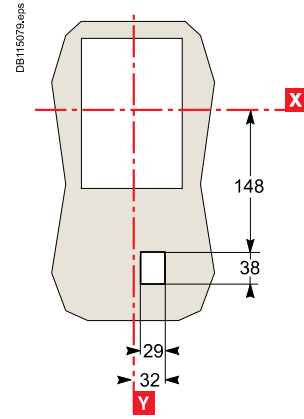
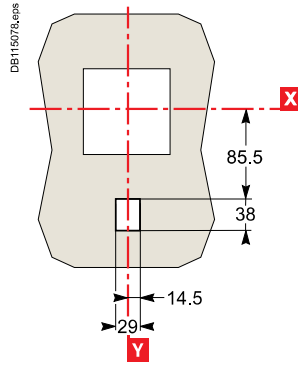
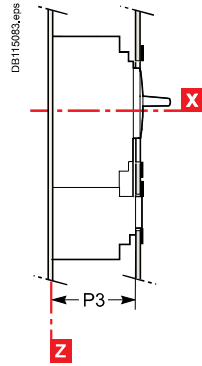
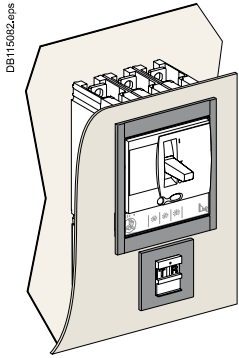

With IP40 front-panel escutcheon

NSX100 to 250

NSX400/630

For toggle

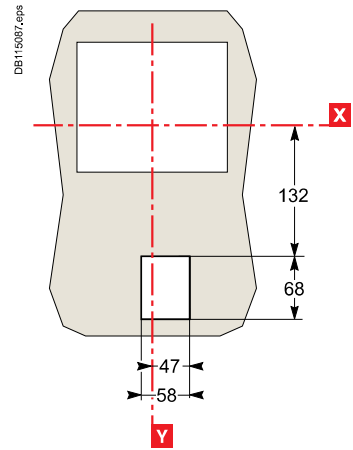
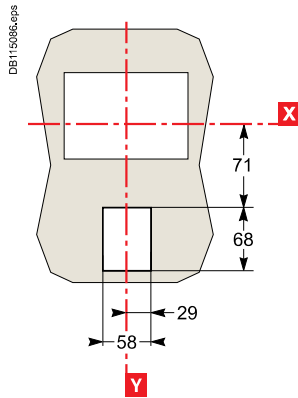
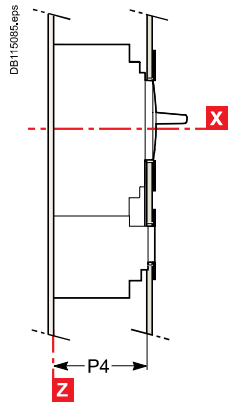
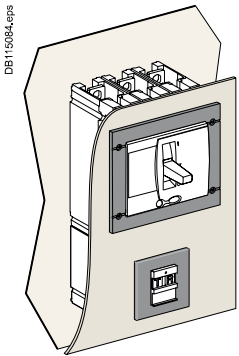

Type	P3	P4
NSX100/160/250	88	89

Note: door cutout dimensions are given for a device position in the enclosure where $\Delta \geq 100 + (h \times 5)$ with respect to the door.

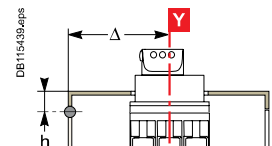

Front-panel cutouts

Compact NSX100 to 630 plug-in and withdrawable versions

Plug-in version

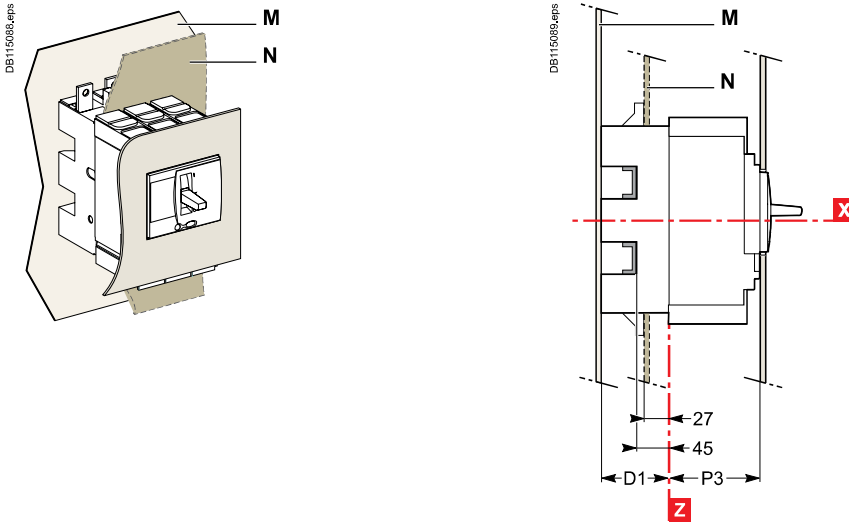

Bare sheet metal

See Compact NSX100 to 630 fixed version, [page C-24](#)

With IP30 front-panel escutcheon

See Compact NSX100 to 630 fixed version, [page C-24](#)

With IP40 front-panel escutcheon

See Compact NSX100 to 630 fixed version, [page C-25](#)

With toggle cover

See Compact NSX100 to 630 fixed version, [page C-25](#)

Withdrawable version

NSX100 to 250

NSX400/630

With protection collar and IP40 front-panel escutcheon

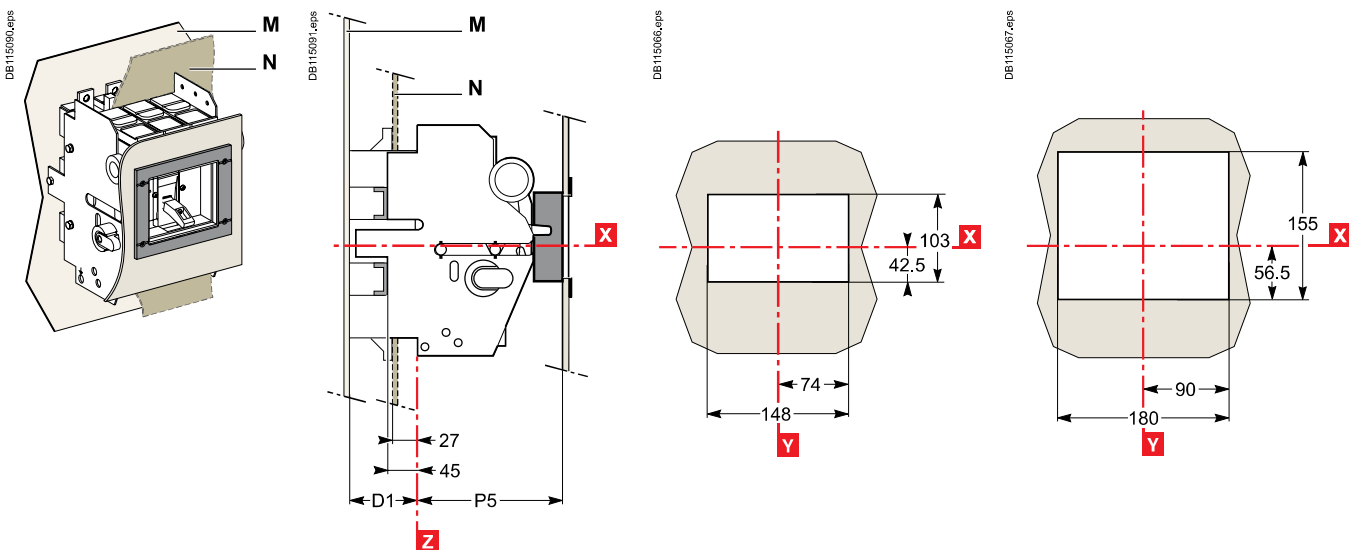

Vigicomact NSX100 to 630 plug-in and withdrawable versions

Plug-in version

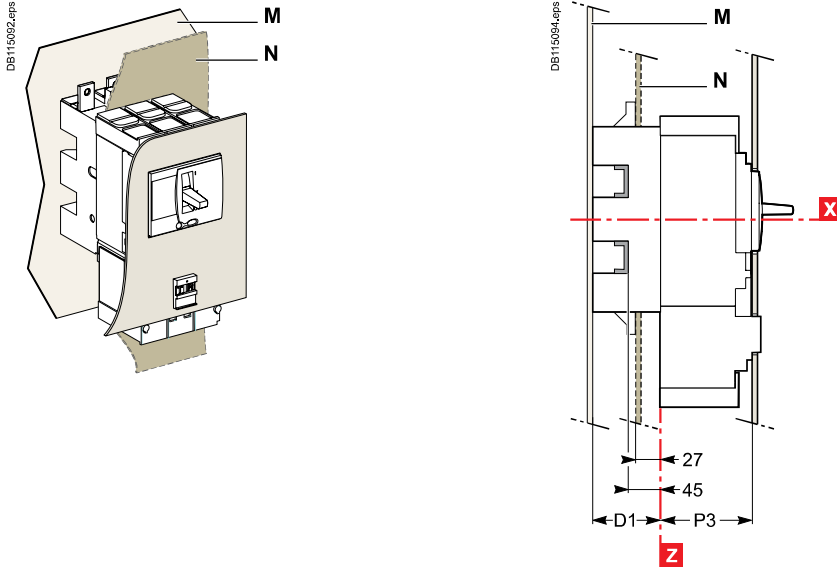

Bare sheet metal

See Compact NSX100 to 630 fixed version, [page C-26](#)

With IP30 front-panel escutcheon

See Compact NSX100 to 630 fixed version, [page C-26](#)

With IP40 front-panel escutcheon

See Compact NSX100 to 630 fixed version, [page C-27](#)

Withdrawable version

NSX100 to 250

NSX400/630

With protection collar and IP40 front-panel escutcheon

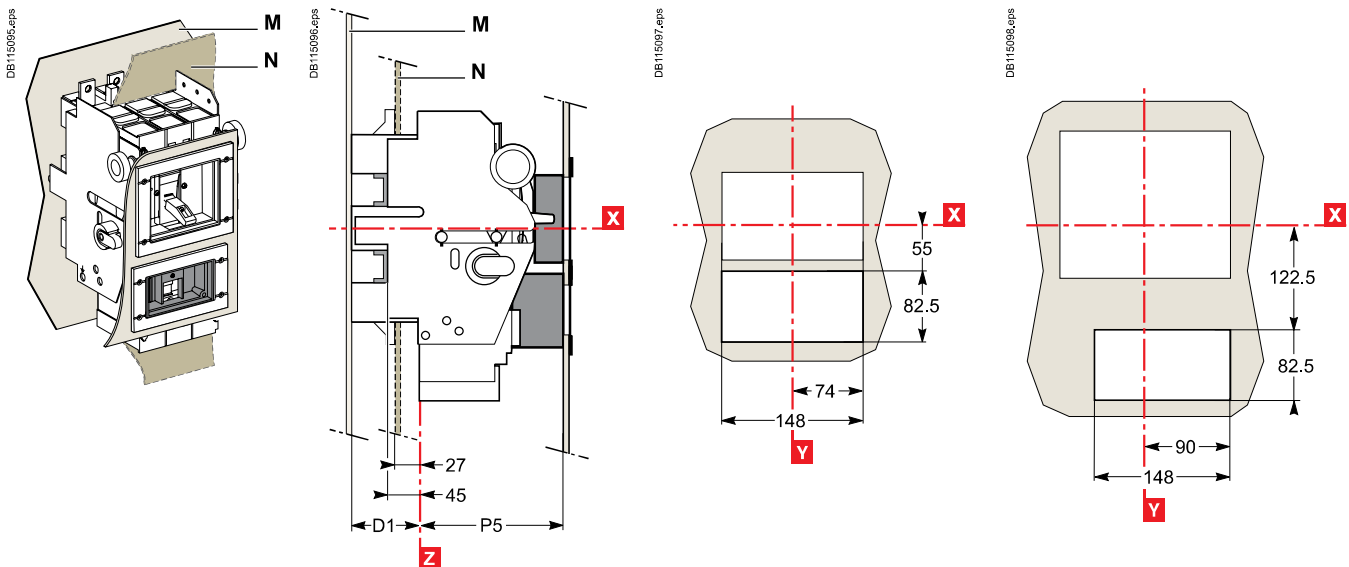

Type	D1	P3	P5
NSX100/160/250	75	88	123

Note: door cutout dimensions are given for a device position in the enclosure where $A \geq 100 + (h \times 5)$ with respect to the door.

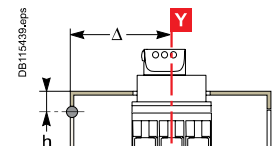

Front-panel cutouts

Visu function for Compact NSX100 to 630 fixed version

Compact NSX100 to 250 with Compact INV100 to 250 Visu function

Bare sheet metal

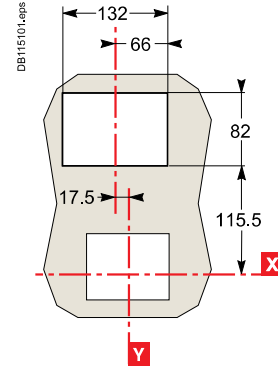
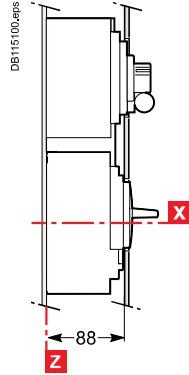
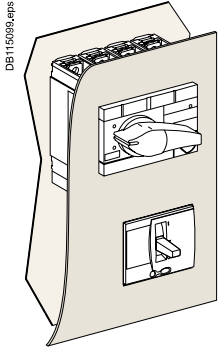

With IP40 front-panel escutcheon

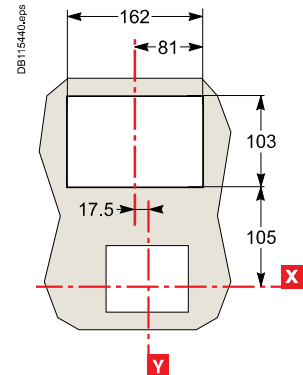
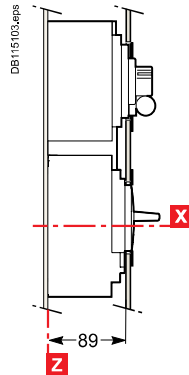
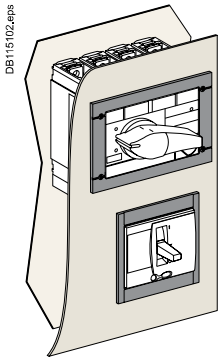

Compact NSX400/630 with Compact INV400 to 630 Visu function

Bare sheet metal

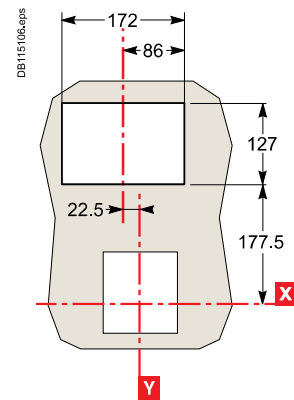
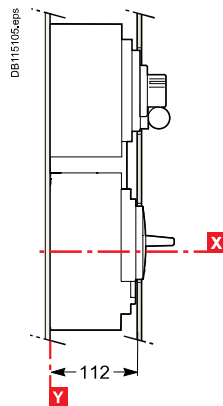
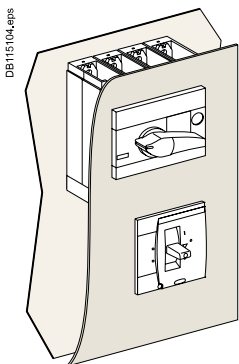

With IP40 front-panel escutcheon

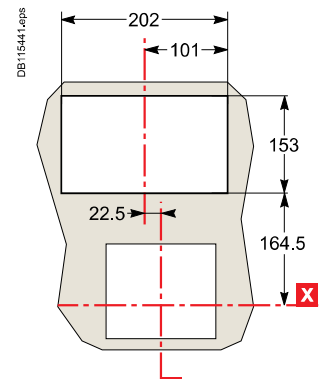
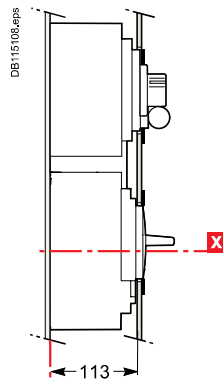
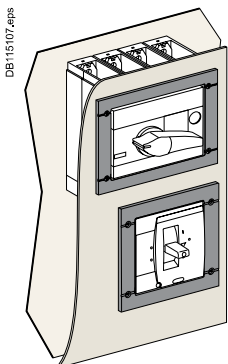

Motor mechanism module for Compact and Vigicompact NSX100 to 630

Bare sheet metal

NSX100 to 250

NSX400/630

Fixed, plug-in or withdrawable circuit breaker

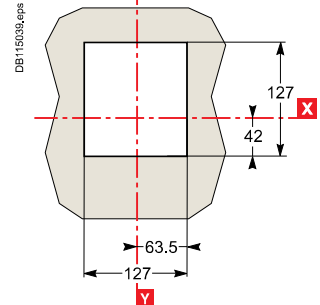
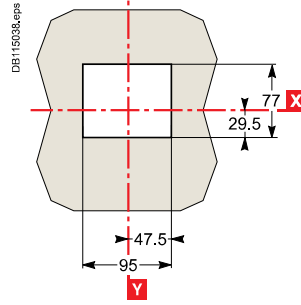
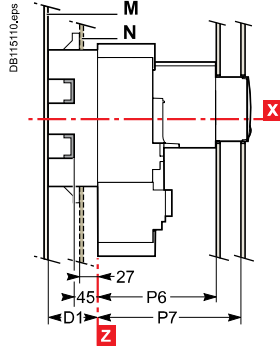
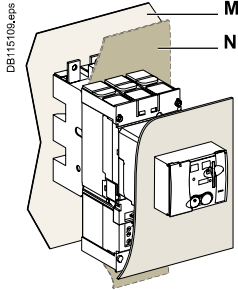

With IP30 front-panel escutcheon

NSX100 to 250

NSX400/630

Fixed, plug-in or withdrawable circuit breaker

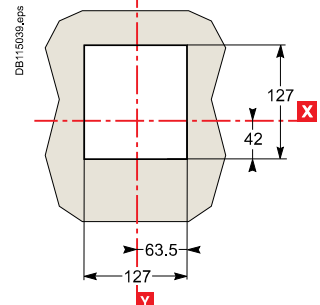
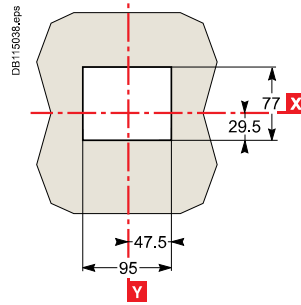
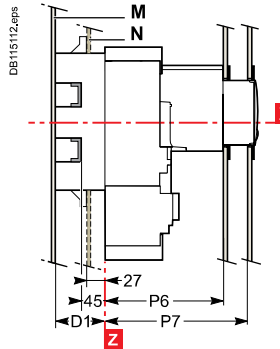
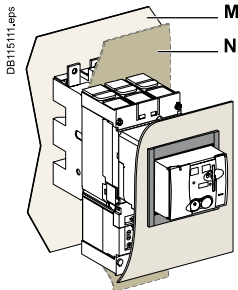

With IP40 front-panel escutcheon

NSX100 to 250

NSX400/630

Fixed, plug-in or withdrawable circuit breaker without access to Vigi module

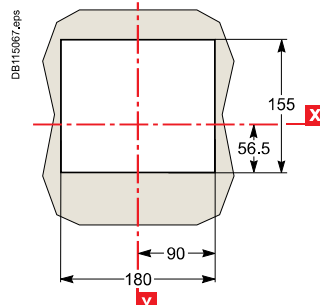
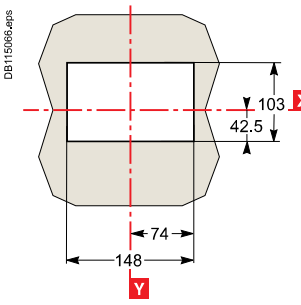
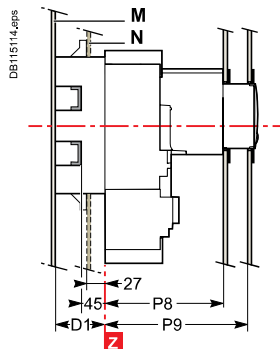
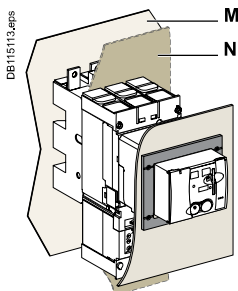

Fixed or plug-in circuit breaker with access to Vigi module

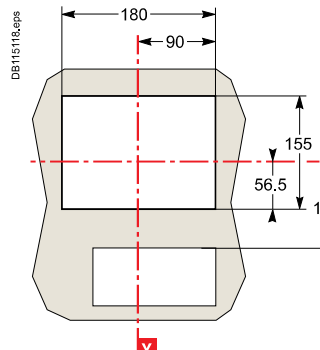
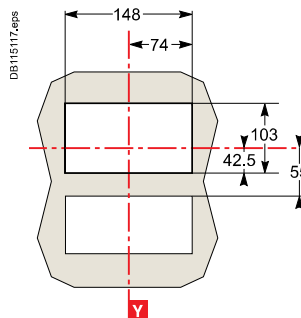
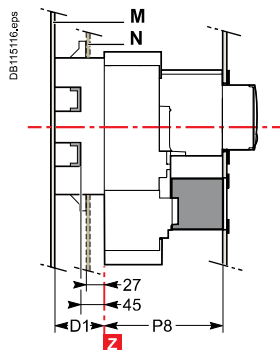
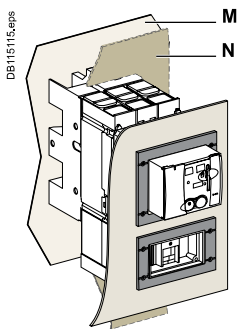

Type	D1	P6 (1)	P7 (2)	P8 (1)	P9 (2)
NSX100/160/250	75	145	177	146	178

(1) Plug-in version.

Front-panel cutouts

Direct rotary handle for Compact and Vigicompact NSX100 to 630

Fixed or plug-in circuit breakers

NSX100 to 250

NSX400/630

Bare sheet metal

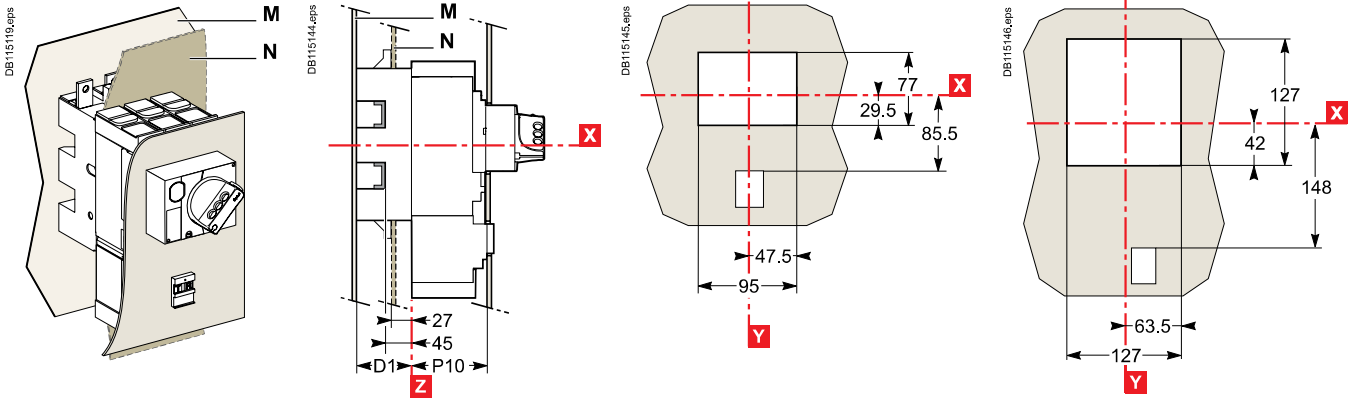

Bare sheet metal with access to the trip unit

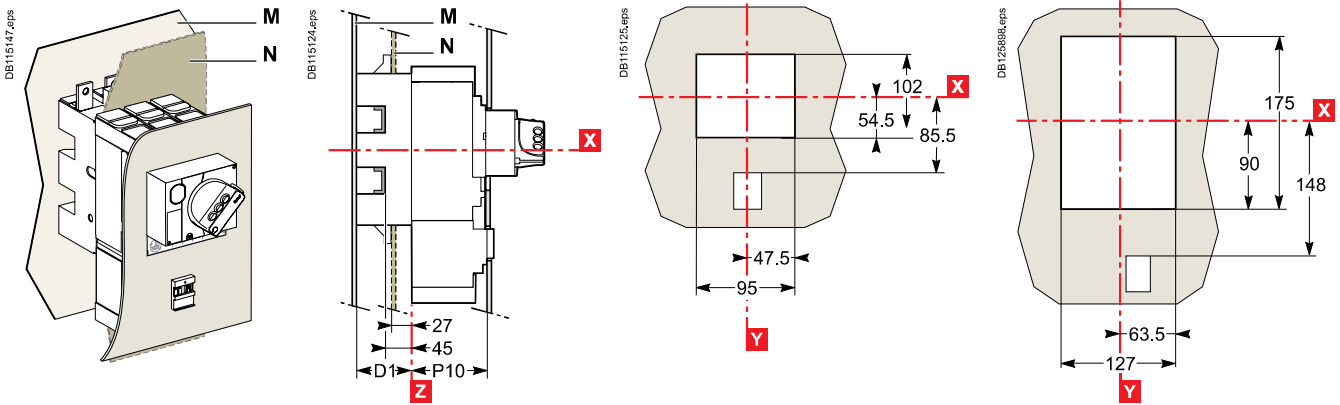

With IP30 front-panel escutcheon

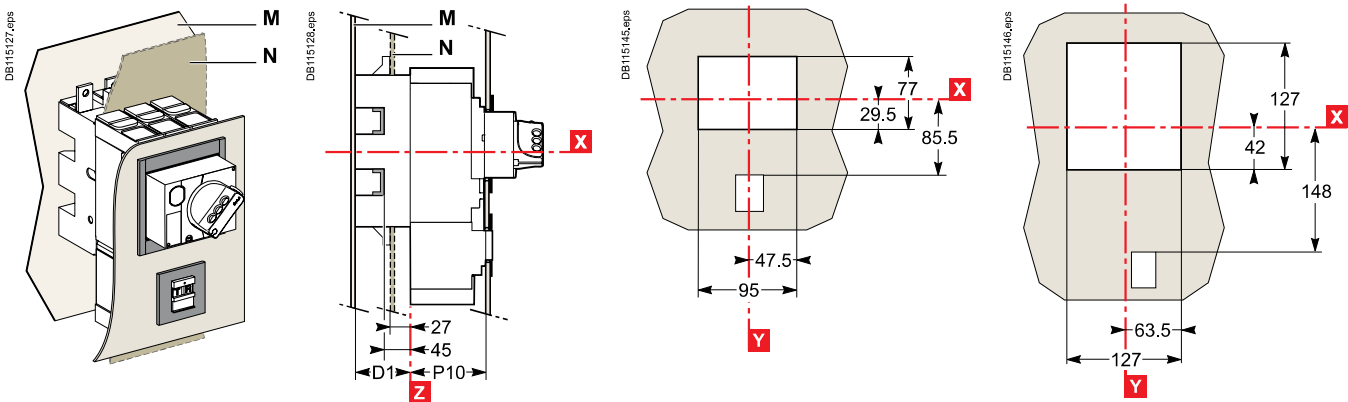

Fixed or plug-in circuit breakers (cont.)

NSX100 to 250

NSX400/630

With IP30 front-panel escutcheon with access to the trip unit

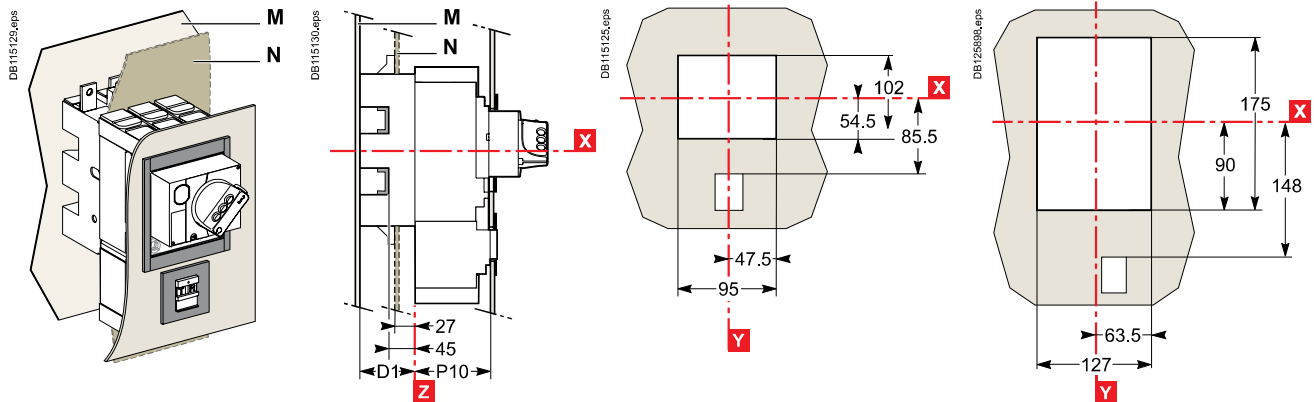

With IP40 front-panel escutcheon

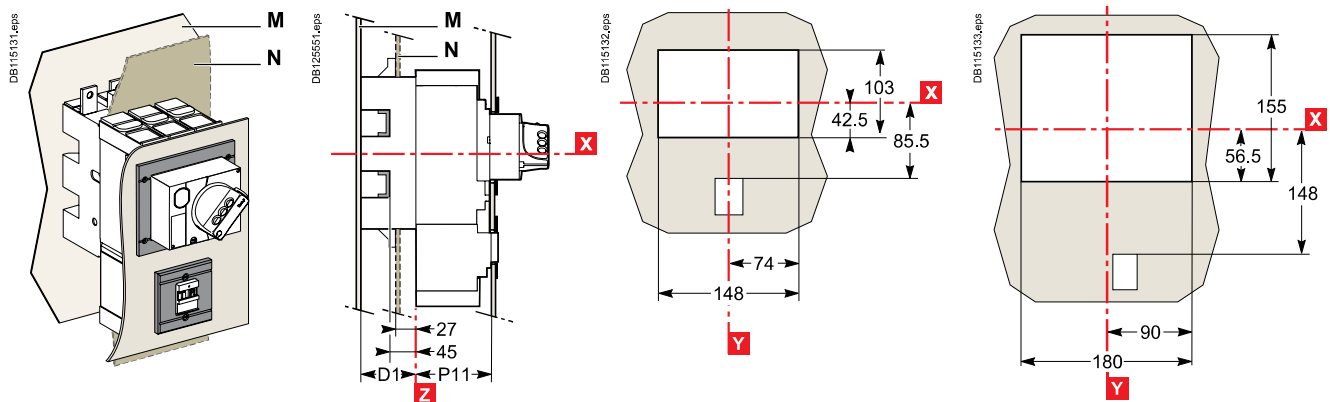

Fixed or withdrawable circuit breakers

NSX100 to 250

NSX400/630

With IP40 front-panel escutcheon

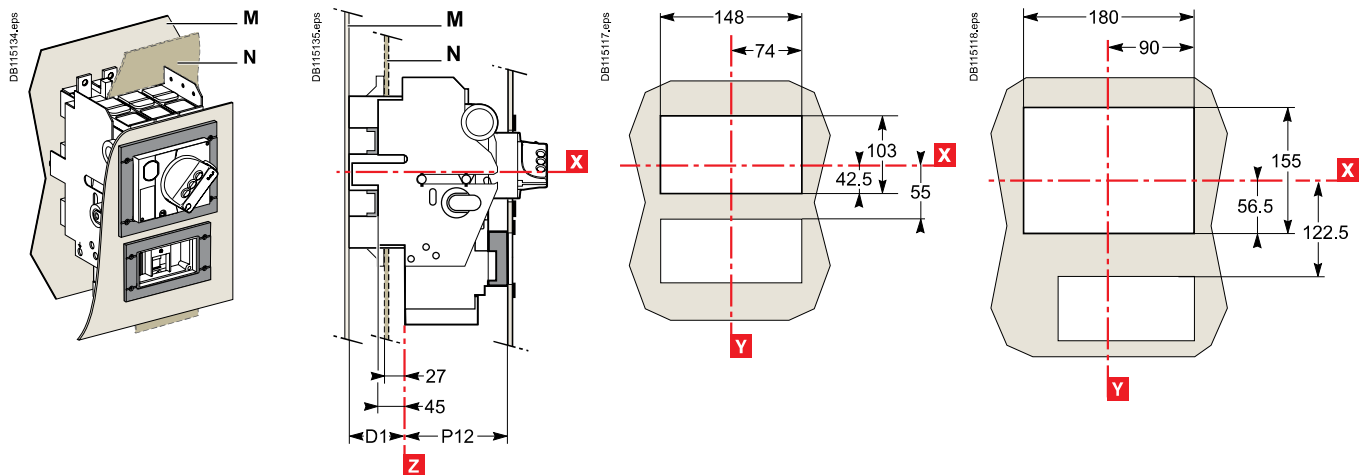

Type	D1	P10	P11	P12
NSX100/160/250	75	89	90	123

Front-panel cutouts

Indication and measurement modules for Compact NSX100 to 630

Fixed or plug-in circuit breakers with ammeter module and voltage-presence indicator

Bare sheet metal

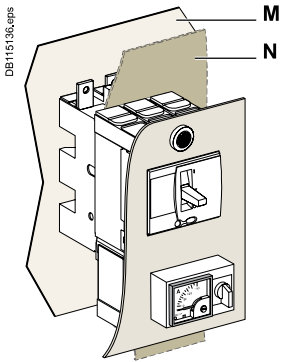

With toggle

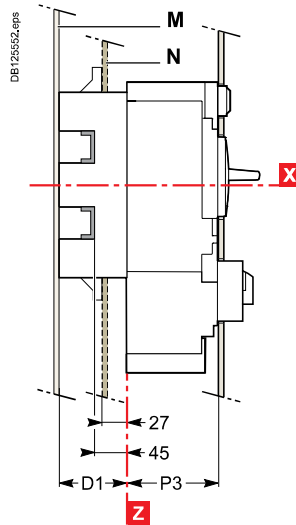

Rotary handle

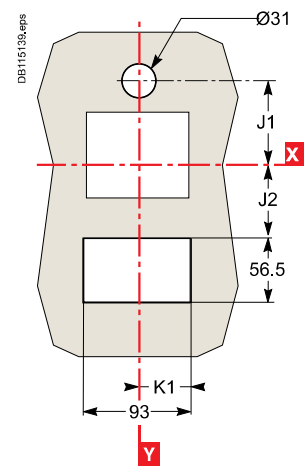
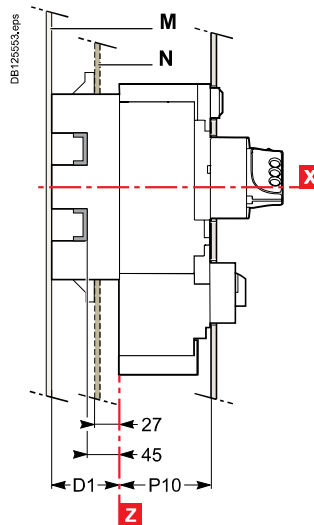

Type	D1	J1	J2	J3	K1	K2	P3	P4	P10	P11
NSX100/160/250	75	78.5	67.5	55	46.5	74	88	89	89	90

Front-panel cutouts

Indication and measurement modules for Compact NSX100 to 630

Fixed or plug-in circuit breakers with ammeter module and voltage-presence indicator

With IP40 front-panel escutcheon

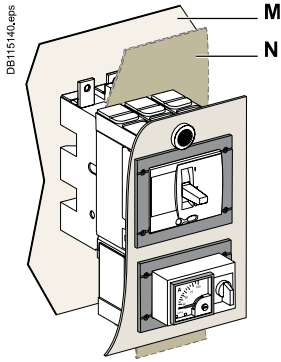

With toggle

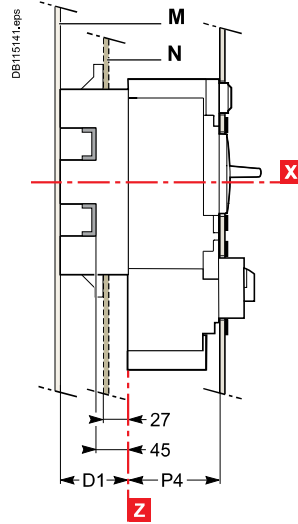

Rotary handle

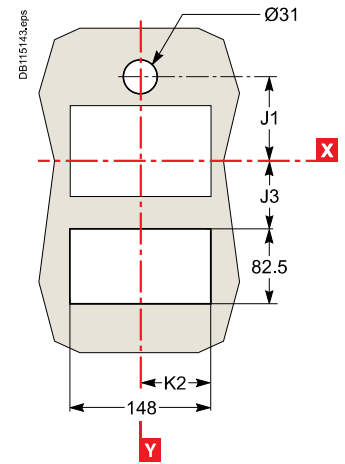
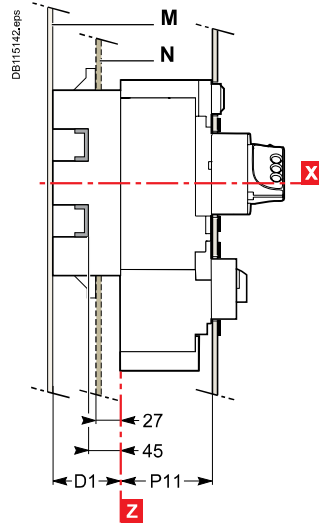

Type	D1	J1	J2	J3	K1	K2	P3	P4	P10	P11
NSX100/160/250	75	78.5	67.5	55	46.5	74	88	89	89	90

Connection locations

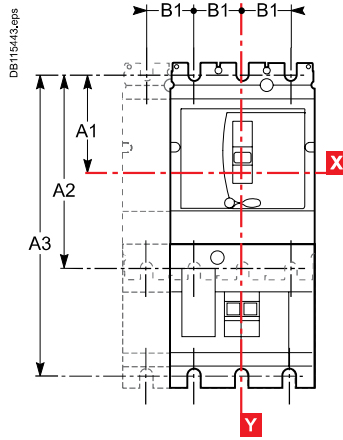
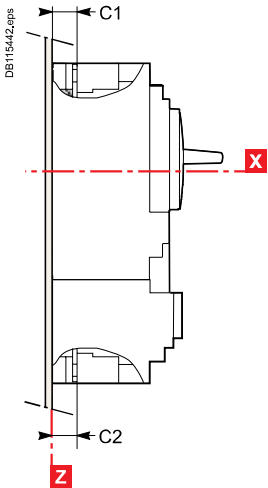

Type	A1	A2	B1	C1	C2
NSX100/160	70	140	35	19.5	19.5
NSX250	70	140	35	21.5	19.5
NSX400/630	113.5	227	45	26	26

Type	A1	A3	B1	C1	C2
NSX100/160 + Vigi	70	215	35	19.5	21.5
NSX250 + Vigi	70	215	35	21.5	21.5
NSX400/630 + Vigi	113.5	327	45	26	26

Front connection without accessories

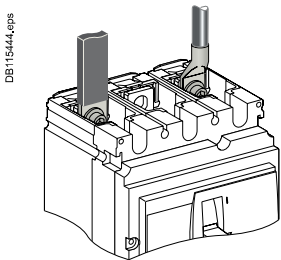

NSX100 to 250

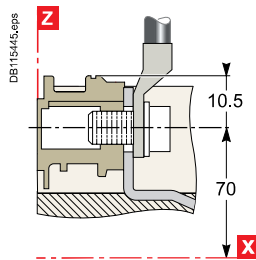

Cables with lugs/bars

NSX400/630

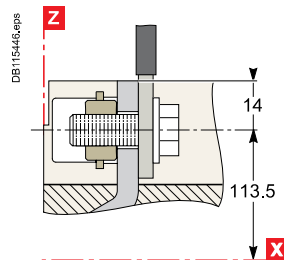

Bars/cables with lugs

Connection with accessories

Long and short rear connectors

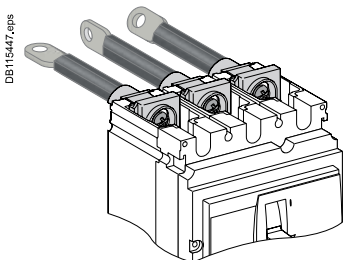

NSX100 to 250

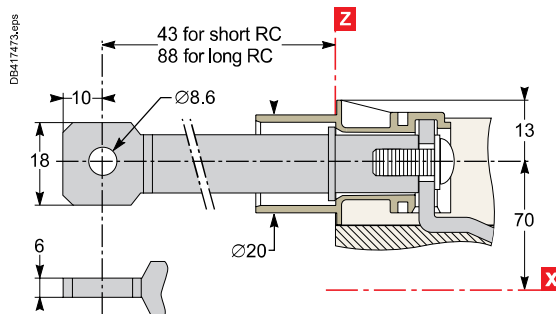

NSX400/630

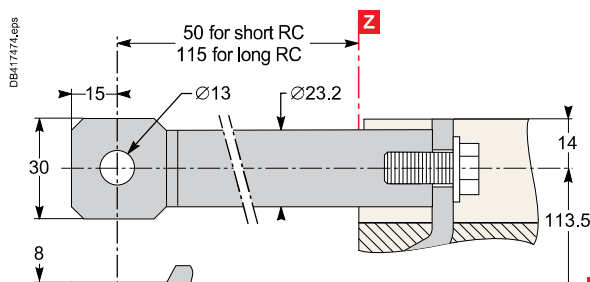

Connection with accessories (cont.)

Bare-cable connectors

DB115450.eps

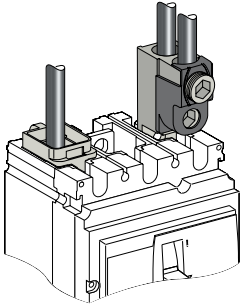

NSX100 to 250

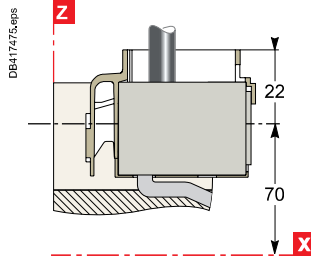

DB417476.eps

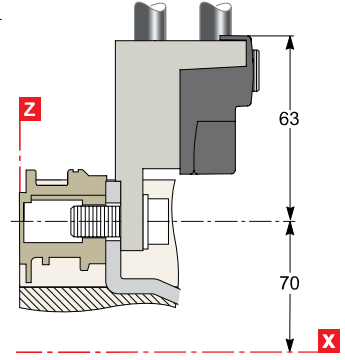

DB115453.eps

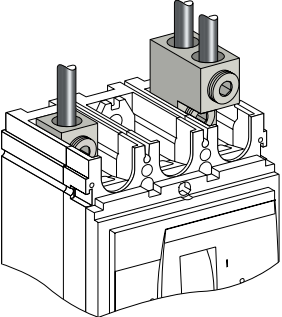

NSX400/630

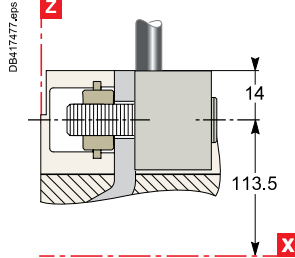

DB417478.eps

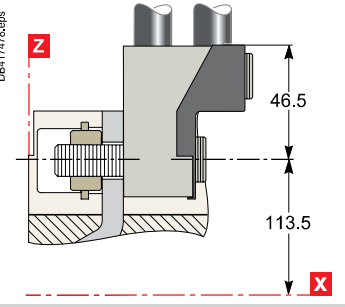

Distribution connectors (for NSX100 to 250 only)

DB115456.eps

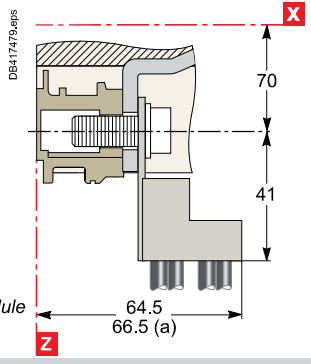
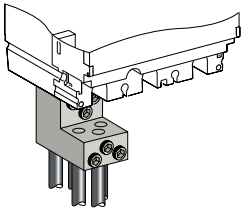

(a) *Vigi* module or NSX250.

Right-angle terminal extensions (upstream only)

DB115458

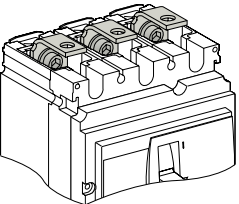

NSX100 to 250

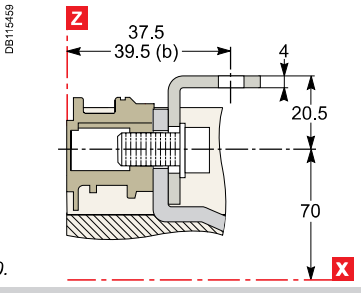

(b) *NSX250*.

NSX400/630

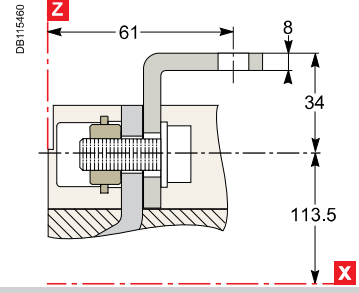

Straight terminal extensions (for NSX100 to 250 only)

DB115461

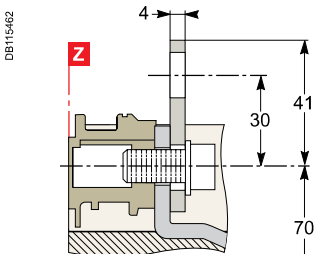
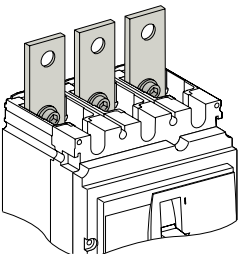

Power connections

Compact and Vigicompact NSX100 to 630 fixed version

Connection with accessories (cont.)

Edgewise terminal extensions

NSX100 to 250

NSX400/630

DB115463.eps

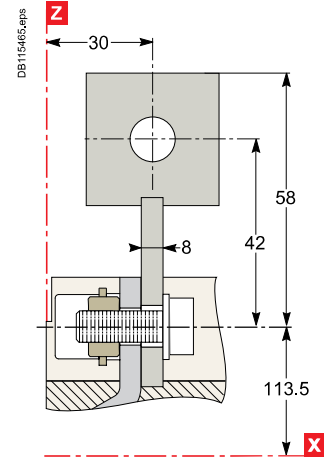
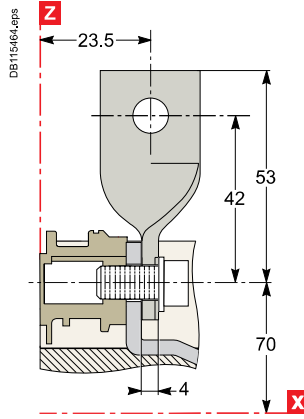
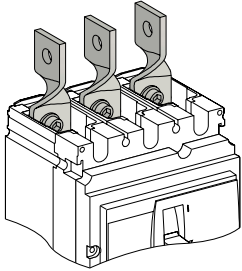

45° terminal extensions

NSX100 to 250

NSX400/630

DB115466.eps

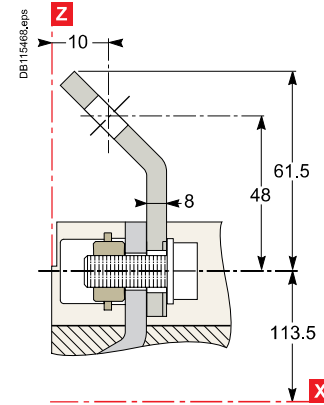
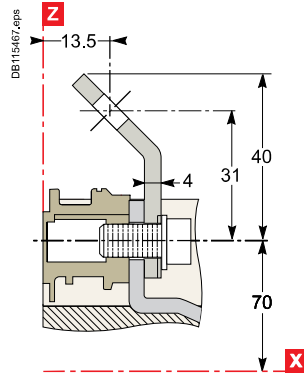
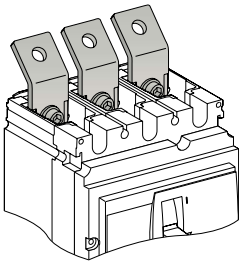

Double-L terminal extensions

NSX100 to 250

DB115469.eps

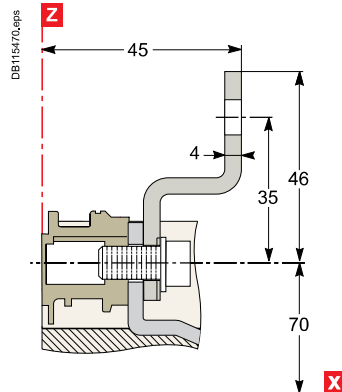
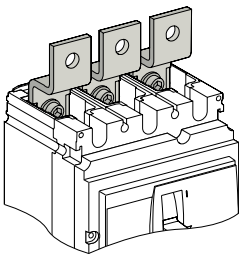

Connection with accessories (cont.)

Spreaders

3P

4P

NSX100 to 250

DB115471.eps

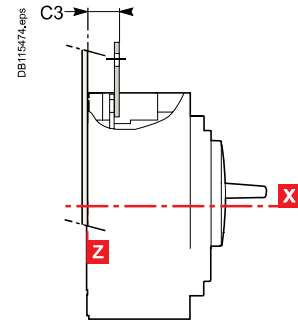
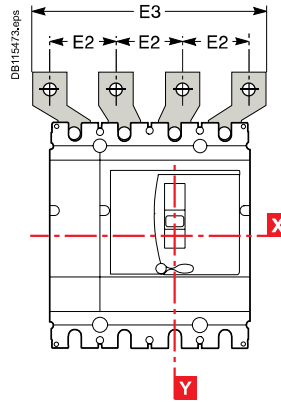
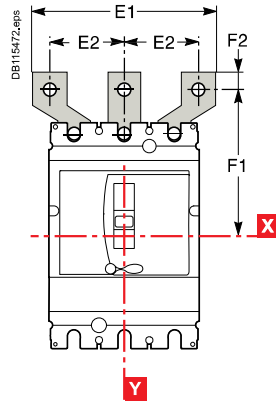
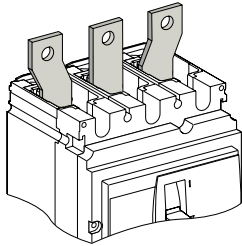

NSX400/630

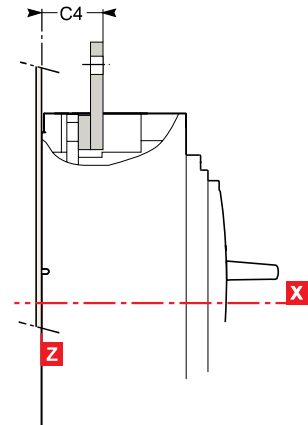

Type	C3	C4	E1	E2	E3	F1	F2
NSX100/160	23.5	-	114	45	159	100	11
NSX250	25.5	-	114	45	159	100	11
NSX400/630	-	44	135	52.5	187.5	152.5	15
			170	70	240	166	15

One-piece spreader (for NSX100 to 250 only)

DB115475.eps

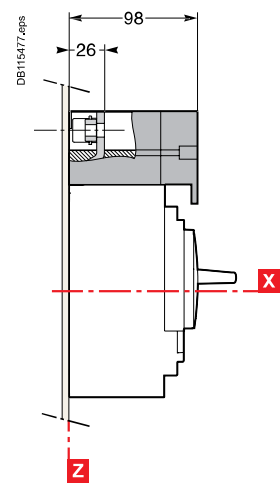
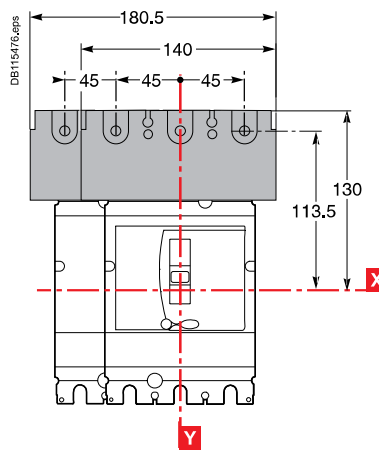
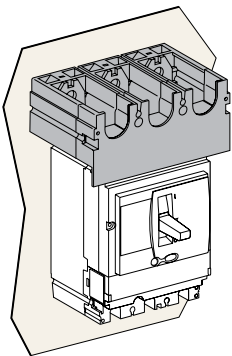

Connection locations

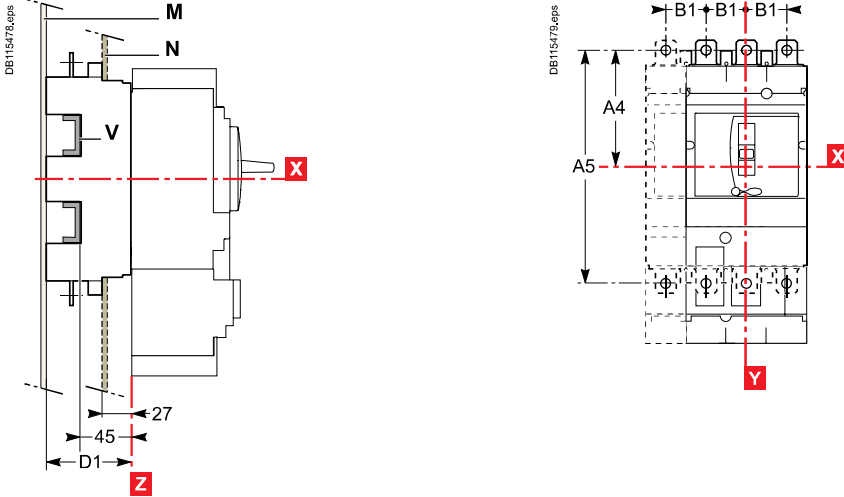

Type	A4	A5	B1	D1
NSX100 to 250	100	200	35	75
NSX400/630	156.5	313	45	100

Note:

- for mounting on a backplate, the insulating screen supplied with the plug-in base must be installed.
- for withdrawable versions, terminal shields are recommended.

Connection without accessories

Front connection: mounting on backplate (M) or rails (V)

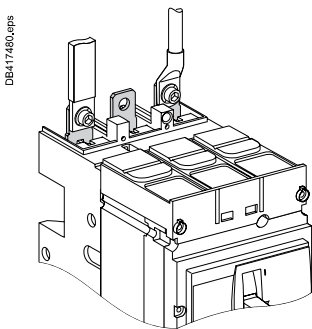

NSX100 to 250

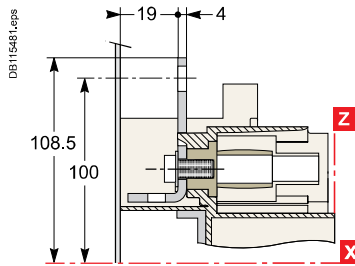

NSX400/630

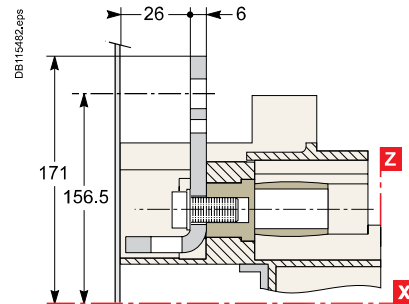

Rear connection: mounting through front panel (N) or on rails (V)

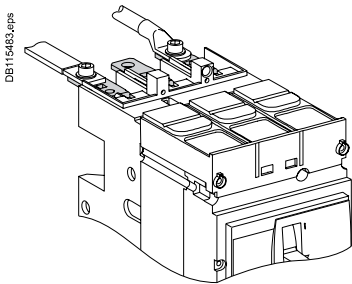

NSX100 to 250

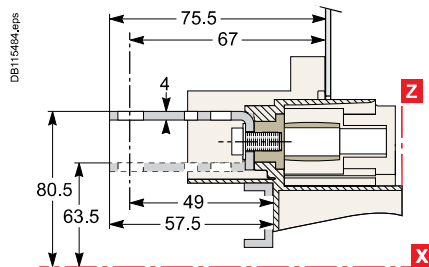

NSX400/630

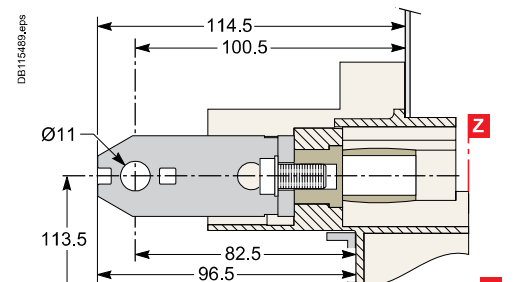
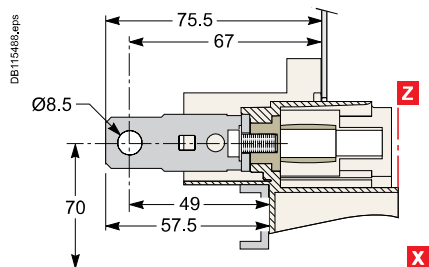
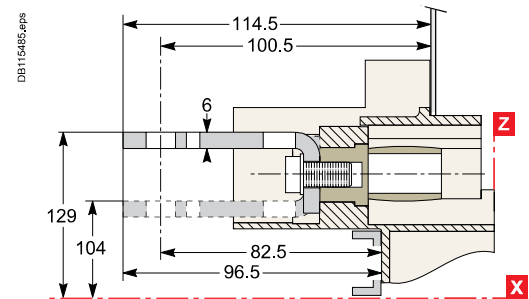

Connection with accessories

Bare-cable connectors: mounting on backplate (M) or rails (V)

DB115430.eps

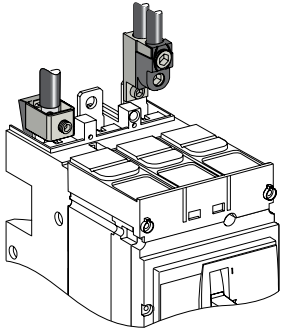

NSX100 to 250

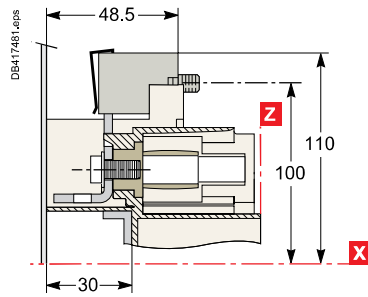

DB417482.eps

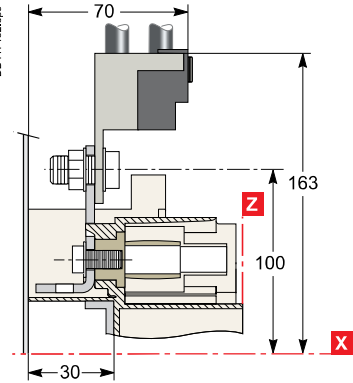

DB115433.eps

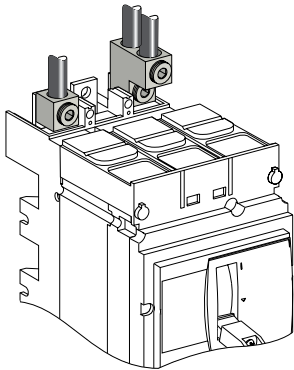

NSX400/630

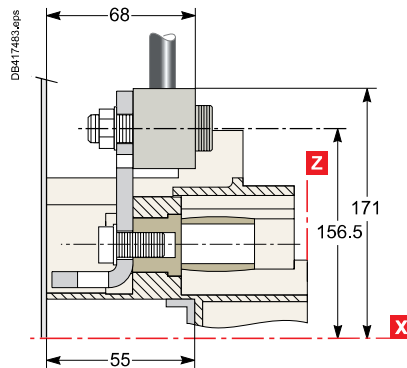

DB417484.eps

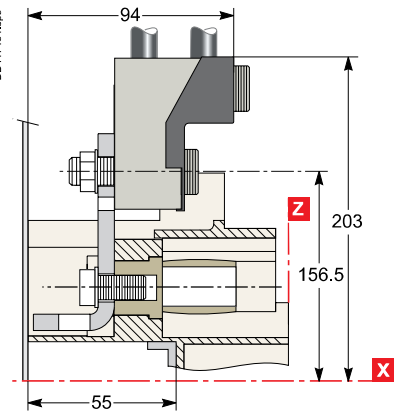

Bare-cable connectors: mounting through front panel (N) or on rails (V)

DB115436.eps

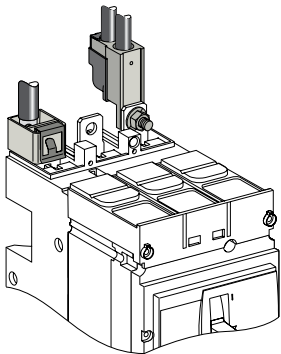

NSX100 to 250

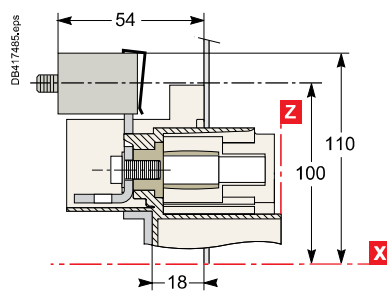

DB417486.eps

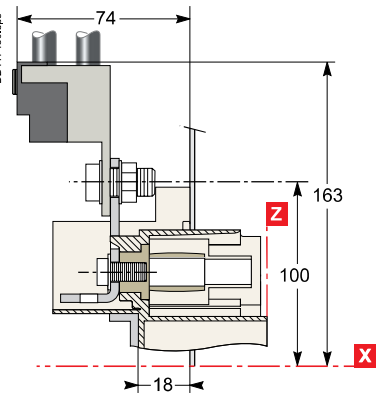

DB115439.eps

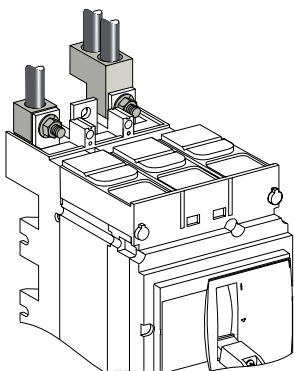

NSX400/630

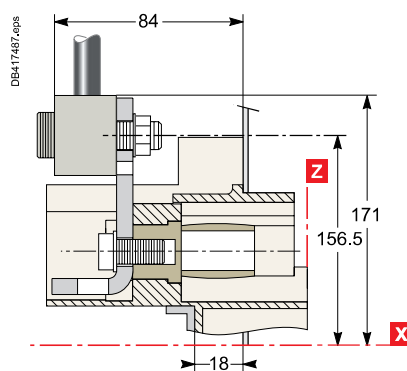

DB417488.eps

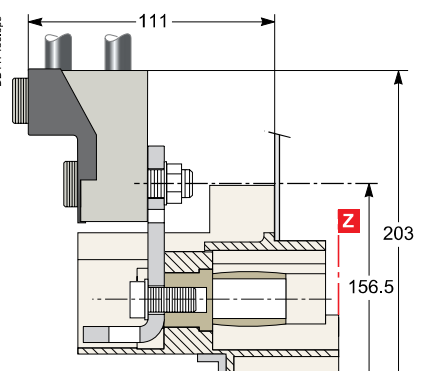

Power connections

Compact and Vigicompact NSX100 to 630 plug-in and withdrawable versions

Connection with accessories (cont.)

45° extensions: mounting through front panel (N) or on rails (V)

DB115506.eps

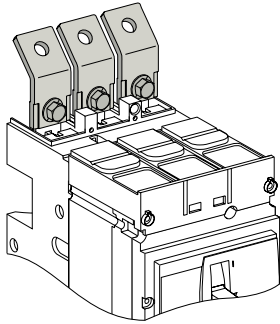

NSX100 to 250

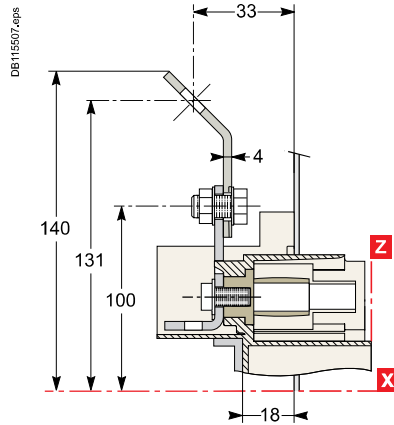

NSX400/630

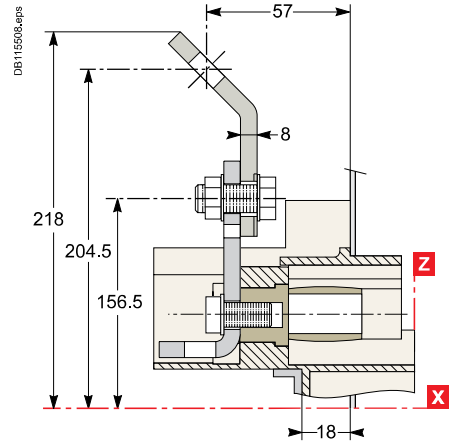

Double-L extensions: mounting on backplate (M) or rails (V)

DB115509.eps

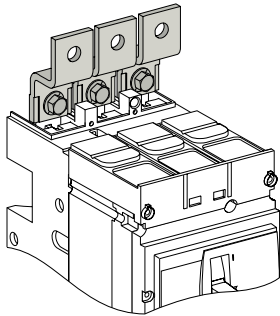

NSX100 to 250

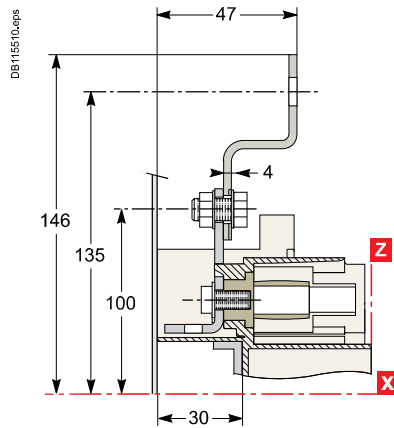

Double-L extensions: mounting through front panel (N) or on rails (V)

NSX100 to 250

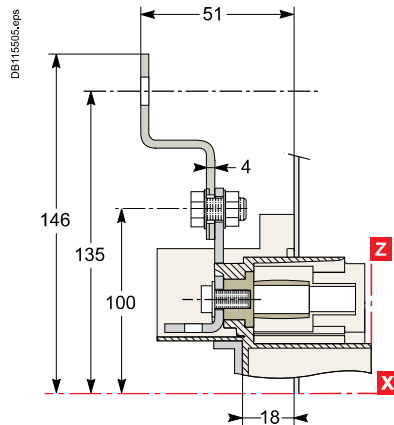

Connection with accessories (cont.)

Spreaders: mounting on backplate (M) or rails (V)

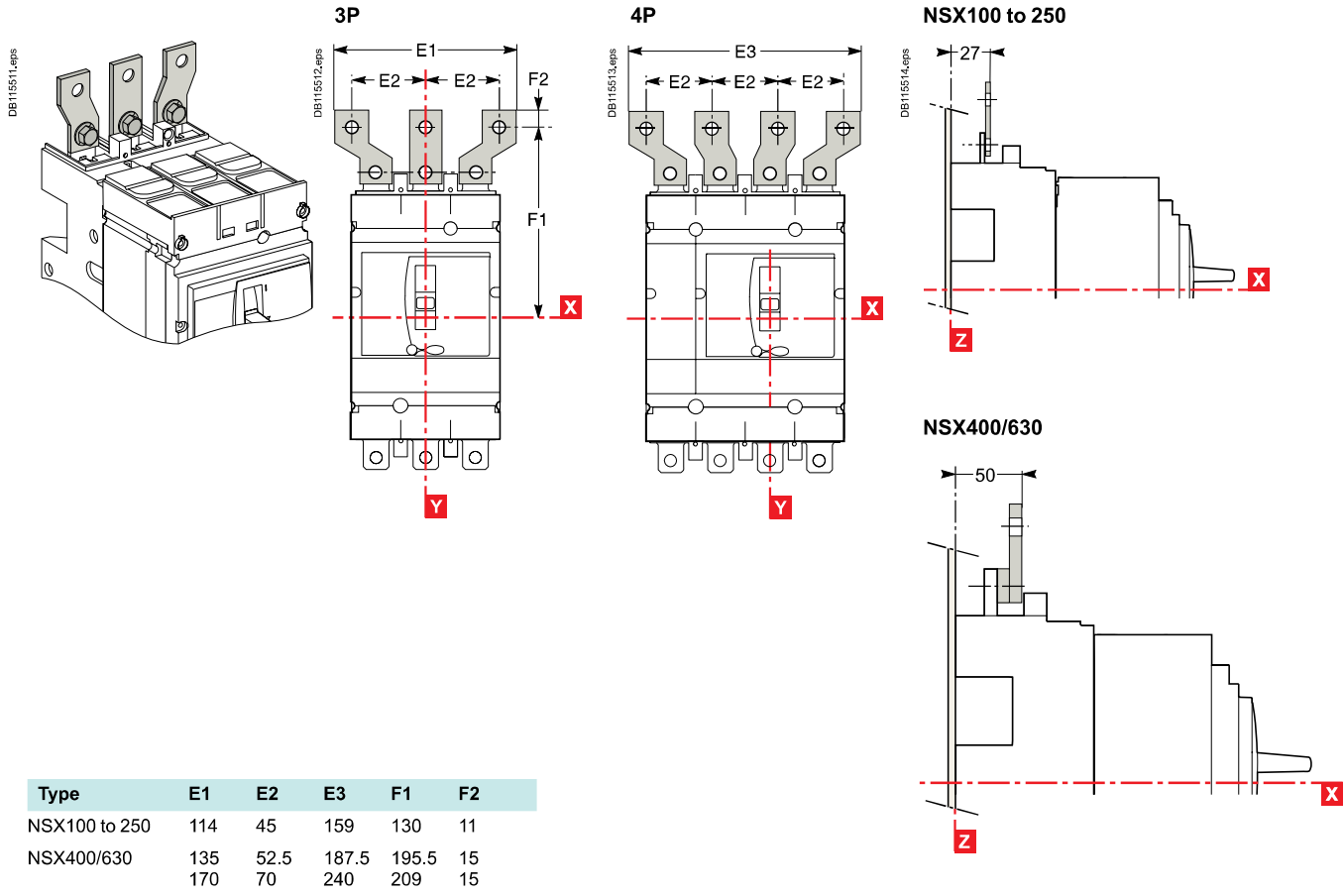

Long insulated rear connectors: mounting on backplate (M) or rails (V)

Exterior-mounted rear connectors

NSX100 to 250

NSX400/630

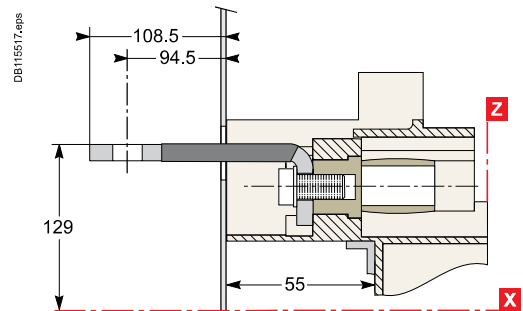
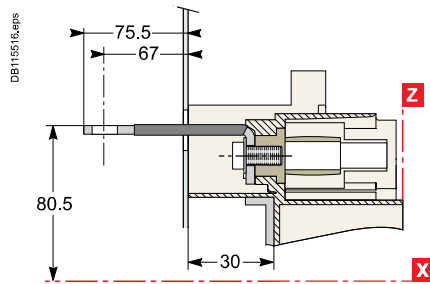
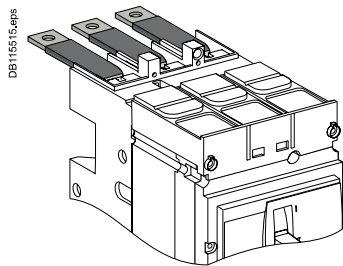

Interior-mounted rear connectors

NSX100 to 250

NSX400/630

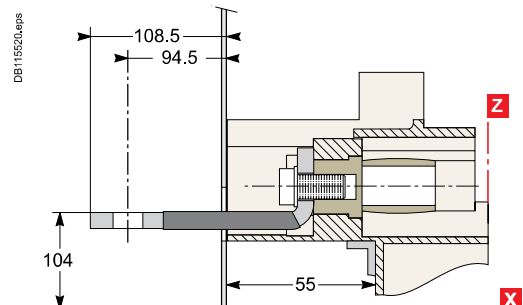
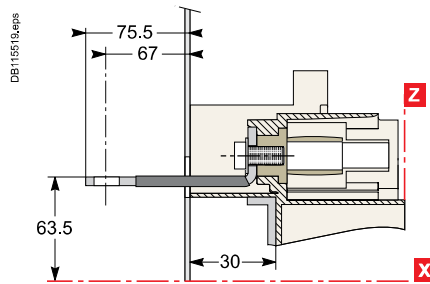
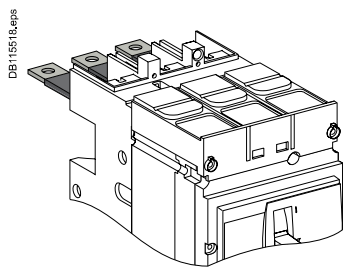

Power connections

Connection of insulated bars or cables with lugs to Compact and Vigicompact NSX100 to 630

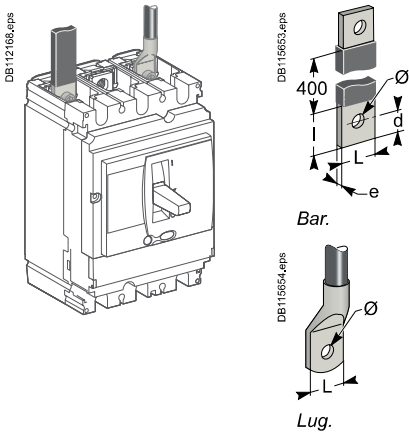

Direct connection for NSX100 to 630

Dimensions		NSX100	NSX160/250	NSX400/630
Bars	L (mm)	≤ 25	≤ 25	≤ 32
	l (mm)	d + 10	d + 10	d + 15
	d (mm)	≤ 10	≤ 10	≤ 15
	e (mm)	≤ 6	≤ 6	3 ≤ e ≤ 10
	Ø (mm)	6.5	8.5	10.5
Lugs	L (mm)	≤ 25	≤ 25	≤ 32
	Ø (mm)	6.5	8.5	10.5
Torque (Nm) ⁽¹⁾		10	15	50
Torque (Nm) ⁽²⁾		5/5	5/5	20/11
Torque (Nm) ⁽³⁾		8	8	20

- (1) Tightening torque on the circuit breaker for lugs or bars.
 (2) Tightening torque on fixed devices for rear connectors/tightening torque on plug-in or withdrawable devices for power connectors.
 (3) Tightening torque on the plug-in base for terminal extensions.

Accessories for NSX100 to 250

Straight terminal extensions

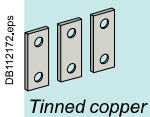

Double-L terminal extensions

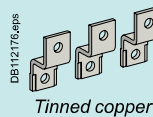

Spreaders: separate parts

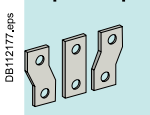

one-piece spreader

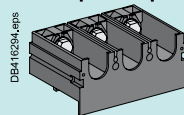

Tinned copper

For U > 600 V, the mandatory insulation kit is not compatible with spreaders made up of separate parts. The one-piece spreader must be used.

Connection with accessories for NSX100 to 250 (IEC 228)

Pole pitch	
Without spreaders	35 mm
With spreaders	45 mm

Dimensions	With spreaders or terminal extensions	
	NSX100	NSX160/250

Bars	L (mm)	≤ 25	≤ 25
	l (mm)	20 ≤ l ≤ 25	20 ≤ l ≤ 25
	d (mm)	≤ 10	≤ 10
	e (mm)	≤ 6	≤ 6
	Ø (mm)	6.5	8.5
Lugs	L (mm)	≤ 25	≤ 25
	Ø (mm)	6.5	8.5
Torque (Nm) ⁽¹⁾		10	15
Torque (Nm) ⁽²⁾		5	5

- (1) Tightening torque on the circuit breaker for spreaders or terminal extensions.
 (2) Tightening torque on the plug-in base for spreaders or terminal extensions.

Spreaders and straight, right-angle, 45°, double-L and edgewise terminal extensions are supplied with flexible interphase barriers.

Accessories for NSX400 and 630

Spreaders made up of separate parts for 52.5 and 70 mm pitch

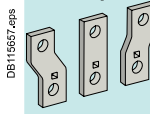

Tinned copper

For U > 600 V, use of the 52.5 mm pitch spreaders requires a specific insulation kit. The 70 mm pitch spreaders may not be used.

Connection with accessories for NSX400 and 630 (IEC 228)

Pole pitch	
Without spreaders	45 mm
With spreaders	52.5 or 70 mm

Dimensions	With spreaders	With terminal extensions
------------	----------------	--------------------------

Bars	L (mm)	≤ 40	≤ 32
	l (mm)	d + 15	30 ≤ l ≤ 34
	d (mm)	≤ 20	≤ 15
	e (mm)	3 ≤ e ≤ 10	3 ≤ e ≤ 10
	Ø (mm)	12.5	10.5
Lugs	L (mm)	≤ 40	≤ 32
	Ø (mm)	12.5	10.5
Torque (Nm) ⁽¹⁾		50	50
Torque (Nm) ⁽²⁾		20	20

- (1) Tightening torque on the circuit breaker for spreaders or terminal extensions.
 (2) Tightening torque on the plug-in base for spreaders or terminal extensions.

Spreaders and right-angle, 45° and edgewise terminal extensions are supplied with flexible interphase barriers.

Accessories for NSX100 to 630

Right-angle terminal extensions

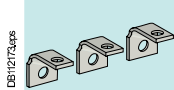

Tinned copper

To be mounted on upstream side.

Edgewise terminal extensions

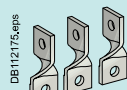

Tinned copper

45° terminal extensions

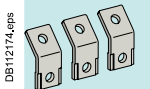

Tinned copper

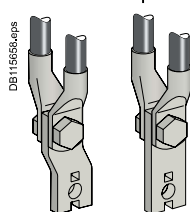

Mounting detail: 2 cables

Connection of bare cables to Compact and Vigicompact NSX100 to 630

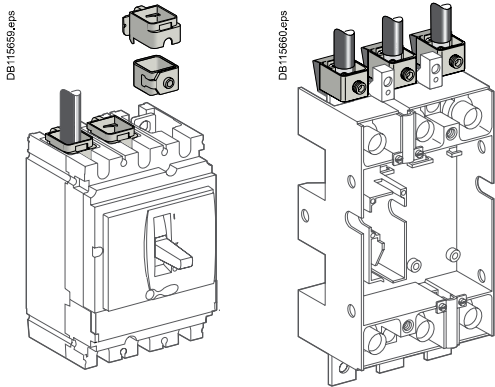

Connection for NSX100 to 250

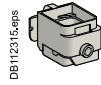

1-cable connector

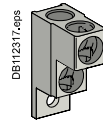

2-cable connector

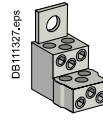

Distribution connector

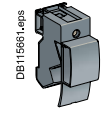

Linergy DP and Linergy DX distribution block

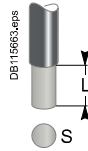
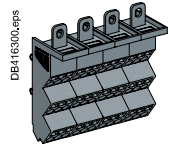

	1-cable connector	Steel ≤ 160 A	Aluminium ≤ 250 A		
L (mm)		25	25		
S (mm ²) Cu / Al		1.5 to 95 ⁽¹⁾	25 to 50	70 to 95	120 to 185 150 max. flex.
Torque (Nm)		12	20	26	26
2-cable connector					
L (mm)		25 or 50			
S (mm ²) Cu / Al		2 x 50 to 2 x 120			
Torque (Nm)		22			
6-cable distribution connector (copper or aluminium)					
L (mm)		15 or 30			
S (mm ²) Cu / Al		1.5 to 6 ⁽¹⁾	8 to 35		
Torque (Nm)		4	6		
Linergy DX and Linergy DP distribution block (6 or 9 cables)					
L (mm)		12	16		
S (mm ²) Cu / Al		6 x 4 to 10	3 x 6 to 16		

⁽¹⁾ For flexible cables from 1.5 to 4 mm², connection with crimped or self-crimping ferrules.

Connection for NSX400 and 630



1-cable connector

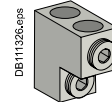

2-cable connector

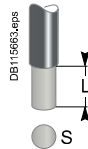

	1-cable connector	2-cable connector
L (mm)	30	30 or 60
S (mm ²) Cu / Al	35 to 300 rigid 240 max. flex.	2 x 35 to 2 x 240 rigid 240 max. flex.
Torque (Nm)	31	31

Conductor materials and electrodynamic stresses

Compact NSX circuit breakers can be connected indifferently with bare-copper, tinned-copper and tinned-aluminium conductors (flexible or rigid bars, cables). In the event of a short-circuit, thermal and electrodynamic stresses will be exerted on the conductors. They must therefore be correctly sized and held in place by supports.

Electrical connection points on switchgear devices (switch-disconnectors, contactors, circuit breakers, etc.) should not be used for mechanical support. Any partition between upstream and downstream connections of the device must be made of non-magnetic material.